

SERVICE MANUAL

AE-3 CHASSIS

MODEL	COMMANDER	DEST.	CHASSIS NO.	MODEL	COMMANDER	DEST.	CHASSIS NO.
<i>KV-29E1A</i>	<i>RM-831</i>	<i>Italian</i>	<i>SCC-J26E-A</i>	<i>KV-29E1E</i>	<i>RM-831</i>	<i>Spanish</i>	<i>SCC-J28E-A</i>
<i>KV-29E1B</i>	<i>RM-831</i>	<i>French</i>	<i>SCC-J27E-A</i>	<i>KV-29E1K</i>	<i>RM-831</i>	<i>OIRT</i>	<i>SCC-J29J-A</i>
<i>KV-29E1D</i>	<i>RM-831</i>	<i>AEP</i>	<i>SCC-J23E-A</i>	<i>KV-29E1R</i>	<i>RM-831</i>	<i>OIRT</i>	<i>SCC-J29K-A</i>

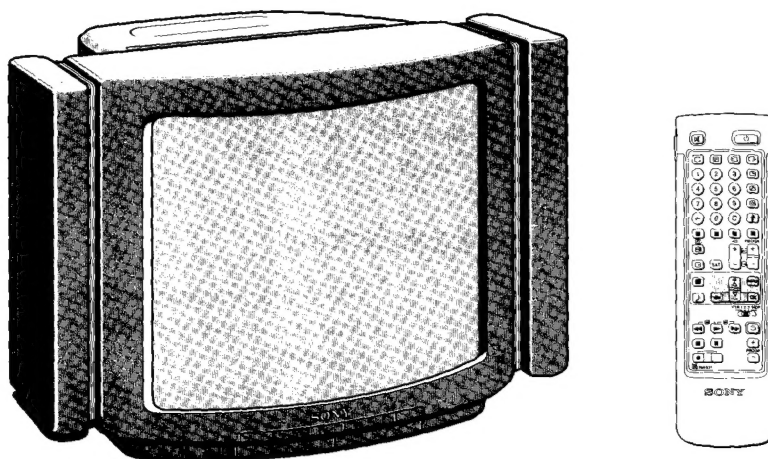

TRINITRON® COLOR TV
SONY®

ITEM MODEL	Television System	Channel Coverage	Colour System
Italian	B/G/H	B/G/H VHF: E2-E12 UHF: E21-E69 Cable TV (1): S1-S41 Cable TV (2): S01-S05, M1-M10, U1-U10 ITALY VHF: A-H UHF: H1, H2	SECAM, PAL NTSC 3.58 (video input only) NTSC4.43 (video input only)
French	B/G/H, D/K, I, L	B/G/H VHF: E2-E12 UHF: E21-E69 Cable TV (1): S1-S41 Cable TV (2): S01-S05, M1-M10, U1-U10 ITALY VHF: A-H UHF: H1, H2 D/K VHF: R01-R12 UHF: R21-R69 I B21-69 L VHF: F2-F10 UHF: F21-F69 Cable TV: B-Q	SECAM, PAL NTSC 3.58 (video input only) NTSC4.43 (video input only)
AEP	B/G/H, D/K	B/G/H VHF: E2-E12 UHF: E21-E69 Cable TV (1): S1-S41 Cable TV (2): S01-S05, M1-M10, U1-U10 ITALY VHF: A-H UHF: H1, H2 D/K VHF: R01-R12 UHF: R21-R69 CABLE TV VHF: B-Q UHF: S21-S41	SECAM, PAL NTSC 3.58 (video input only) NTSC4.43 (video input only)
Spanish	B/G/H, D/K	B/G/H VHF: E2-E12 UHF: E21-E69 Cable TV (1): S1-S41 Cable TV (2): S01-S05, M1-M10, U1-U10 ITALY VHF: A-H UHF: H1, H2 SECAM D/K VHF: R01-R12 UHF: R21-R60	SECAM, PAL NTSC 3.58 (video input only) NTSC4.43 (video input only)
OIRT	B/G/H, D/K	B/G/H VHF: E2-E12 UHF: E21-E69 Cable TV (1): S1-S41 Cable TV (2): S01-S05, M1-M10, U1-U10 ITALY VHF: A-H UHF: H1, H2 SECAM D/K VHF: R01-R12 UHF: R21-R60	SECAM, PAL NTSC 3.58 (video input only) NTSC4.43 (video input only)

MODEL	Italian	French	AEP	Spanish	OIRT
Power Consumption	134W	145W	143W	145W	143W

SPECIFICATIONS

Picture Tube Super Trinitron
Approx. 72 cm (29 inches)
(Approx. 68 cm picture measured diagonally)
110° -deflection

↻ Audio outputs (variable) - phono jacks
External speaker terminals ; 2-pin DIN (3)

[FRONT]

➔ 3 , Video input - phono jack
➔ 3 , Audio inputs - phono jacks
➔ 3 , S video input - 4 pin DIN
🎧 Headphonejack - stereo minijack

Rear/Front Terminals

[REAR]

- ➔ 1 21-pin Euro connector (CENELEC standard)
- Inputs for audio / video signals
- Inputs for RGB
- Outputs of TV audio and video signals
- ➔ 2/ ➔ 2, 21-pin Euro connector
- Inputs for audio and video signals
- Inputs for S video
- Outputs for TV audio and video signals (selectable)
- ➔ 4/ ➔ 4, 21-pin Euro connector
- Inputs for audio and video signals
- Inputs for S video
- Outputs for TV audio and video signals (monitor out)
- ➔ 2, ➔ 4, S video inputs - 4 pin DIN
- ➔ Audio inputs (L,R) - phono jacks
- ➔ S video output - 4 pin DIN
- ↻ Audio outputs - phono jacks

Sound output 2x25W (side speakers)
50W (woofer)

Dimensions 802x550x525 mm approx.
(incl. speakers)

Weight Approx. 53.0 kg (incl. speakers)

Supplied accessories

Remote Commander RM831 (1)
Battery R6 (1)







Other features Digital comb filter (High resolution)
FASTEXT
100Hz Digital Plus
DNR (Digital Noise Reduction)
Scroll Commander (RM-860)
PIP, Multi-PIP

[RM-831]

Remote control system Infrared control
 Power requirements 1.5V dc
 1 battery IEC designation
 R6 (size AA)
 Dimensions Approx. 65x225x21 mm (w/h/d)
 Weight Approx. 157g (Not including battery)

Design and specifications are subject to change without notice.

Item \ Model name	KV-29E1A	KV-29E1B	KV-29E1D	KV-29E1E	KV-29E1K KV-29E1R
PIP	ON	ON	ON	ON	ON
MPIP	ON	ON	ON	ON	ON
Rotation Coil	ON	ON	ON	ON	ON
VM Set	ON	ON	ON	ON	ON
Scart 1	ON	ON	ON	ON	ON
Scart 2	ON	ON	ON	ON	ON
Scart 4	ON	ON	ON	ON	ON
Front AV	ON	ON	ON	ON	ON
DNR (Digital Noise Reduction)	ON	ON	ON	ON	ON
TXT	ON	ON	ON	ON	ON
FLOF	ON	ON	ON	ON	ON
TOP	ON	ON	ON	ON	ON
Norm B/G/H	ON	ON	ON	ON	ON
Norm I	OFF	ON	OFF	OFF	OFF
Norm D/K	OFF	ON	ON	ON	ON
Norm L	OFF	ON	OFF	OFF	OFF
Language Preset	Italian	French	German	Spanish	OIRT

21 pin connector ( 1,  2 /  2,  4 /  4,  2,  4)

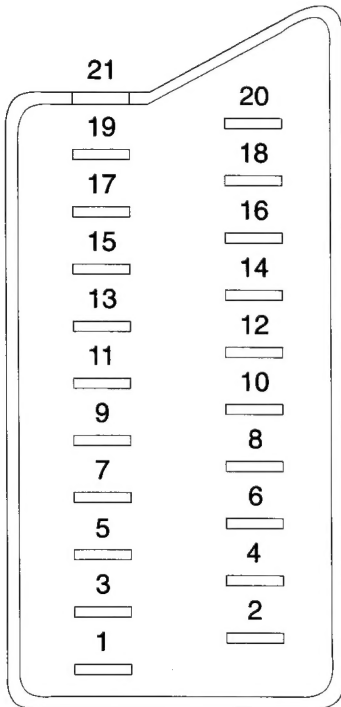
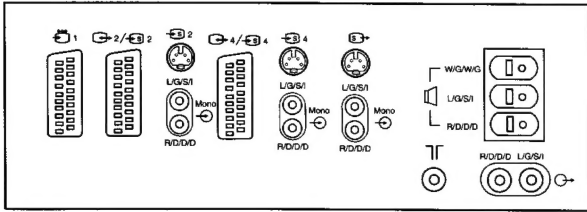

Pin No.	1	2	4	Signal	Signal Level
1	○	○	○	Audio output B (Right)	Standard level : 0.5V rms Output impedance : Less than 1k ohms*
2	○	○	○	Audio input B (Right)	Standard level : 0.5V rms Output impedance : More than 10k ohms*
3	○	○	○	Audio output A (Left)	Standard level : 0.5V rms Output impedance : Less than 1k ohm*
4	○	○	○	Ground (Audio)	
5	○	○	○	Ground (Blue)	
6	○	○	○	Audio input A (Left)	Standard level : 0.5V rms Output impedance : Less than 10k ohm*
7	○	●	●	Blue input	0.7 ± 3dB, 75 ohms, positive
8	○	○	○	Function select (AV control)	High state (9.5 - 12V) : Part mode Low state (0 - 2V) : TV mode Input impedance : More than 10k ohms Input capacitance : Less than 2nF
9	○	○	○	Ground (Green)	
10	○	○	○	Open	
11	○	●	●	Green	
12	○	○	○	Open	
13	○	○	○	Ground (Red)	
14	○	○	○	Ground (Blanking)	
15	○	—	—	Red input	0.7 ± 3dB, 75 ohms, positive
	—	○	○	(S signal) chroma input	0.7 ± 3dB, 75 ohms, positive
16	○	●	●	Blanking input (Ys signal)	High state (1 - 3V) Low state (0 - 0.4V) Input impedance : 75 ohms
17	○	○	○	Ground (Video output)	
18	○	○	○	Ground (Video input)	
19	○	○	○	Video output	1V ± 3dB, 75ohms, positive sync : 0.3V (-3 + 10dB)
20	○	—	—	Video input	1V ± 3dB, 75ohms, positive sync : 0.3V (-3 + 10dB)
	—	○	○	Video input Y (S signal)	1V ± 3dB, 75ohms, positive sync : 0.3V (-3 + 10dB)
21	○	○	○	Common ground (plug, shield)	

○ Connected ● Not Connected (Open) * at 20Hz - 20kHz

Pin No.	Signal	Signal Level
1	Ground	
2	Ground	
3	Y (S signal) input	1V ± 3dB 75 ohm, positive Sync. 0.3V -3 + 10dB
4	C (S signal) input	0.3V ± 3dB 75ohm, positive Sync.

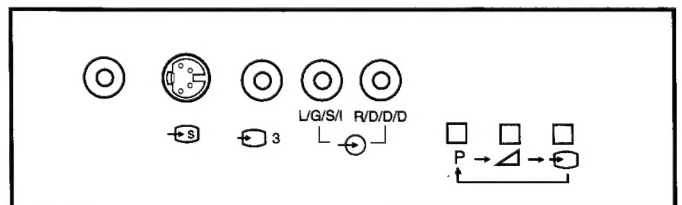

TABLE OF CONTENTS

<u>Section</u>	<u>Title</u>	<u>Page</u>	<u>Section</u>	<u>Title</u>	<u>Page</u>
1. GENERAL			5. DIAGRAMS		
	Getting Started	6	5-1.	Block Diagrams	31
	Additional Presetting Functions	8	5-2.	Circuit Boards Location	41
	Operating Instructions	10	5-3.	Schematic Diagrams and Printed Wiring Boards	41
	Adjusting and Setting the TV Using the Menu	11		* A Board	47
	PIP (Picture in Picture)	12		* J Board	57
	Teletext	13		* H1, H2, F1 Board	60
	Connecting and operating Optional Equipment	15		* B Board	64
	For Your Information	16		* G Board	78
				* D Board	83
2. DISASSEMBLY				* VM Board	87
2-1.	Rear Cover Removal	17		* C Board	88
2-2.	Chassis Assy and H Bracket Removal	17		* IF Block [IFH-389FX] (KV-29E1B only)	91
2-3.	Service Position	17		* IF Block [IFH-389WE] (KV-29E1A, 29E1D, 29E1E, 29E1K and 29E1R only)	93
2-4.	G and J Board Removal	17	5-4.	Semiconductors	97
2-5.	Wire Dressing	18			
2-6.	Picture Tube Removal	18			
3. SET-UP ADJUSTMENTS			6. EXPLODED VIEWS		
3-1.	Beam Landing	19	6-1.	Chassis	100
3-2.	Convergence	20	6-2.	Picture Tube	101
3-3.	Focus	22	6-3.	Box Speakers	102
3-4.	Screen (G2), White Balance (Adjustment in the service mode with remote commander	22	7. ELECTRICAL PARTS LIST		103
4. CIRCUIT ADJUSTMENTS					
4-1.	Electrical Adjustments	23			
4-2.	Volume Electrical Adjustments	26			
4-3.	Test Mode 2 :	27			
4-4.	Error Monitor and Detection	29			
4-5.	LED Error Blinking	30			

CAUTION

SHORT CIRCUIT THE ANODE OF THE PICTURE TUBE AND THE ANODE CAP TO THE METAL CHASSIS, CRT SHIELD, OR CARBON PAINTED ON THE CRT, AFTER REMOVING THE ANODE.

WARNING !!

AN ISOLATION TRANSFORMER SHOULD BE USED DURING ANY SERVICE TO AVOID POSSIBLE SHOCK HAZARD, BECAUSE OF LIVE CHASSIS.
THE CHASSIS OF THIS RECEIVER IS DIRECTLY CONNECTED TO THE AC POWER LINE.

SAFETY-RELATED COMPONENT WARNING !!

COMPONENTS IDENTIFIED BY SHADING AND MARK  ON THE SCHEMATIC DIAGRAMS, EXPLODED VIEWS AND, IN THE PARTS LIST ARE CRITICAL FOR SAFE OPERATION. REPLACE THESE COMPONENTS WITH SONY PARTS WHOSE PART NUMBERS APPEAR AS SHOWN IN THIS MANUAL OR IN SUPPLEMENTS PUBLISHED BY SONY.

ATTENTION

APRES AVOIR DECONNECTE LE CAP DE L'ANODE, COURT-CIRCUITER L'ANODE DU TUBE CATHODIQUE ET CELUI DE L'ANODE DU CAP AU CHASSIS METALLIQUE DE L'APPAREIL, OU AU COUCHE DE CARBONE PEINTE SUR LE TUBE CATHODIQUE OU AU BLINDAGE DU TUBE CATHODIQUE.

ATTENTION !!

AFIN D'EVITER TOUT RISQUE D'ELECTROCUTION PROVENANT D'UN CHÂSSIS SOUS TENSION, UN TRANSFORMATEUR D'ISOLEMENT DOIT ETRE UTILISÉ LORS DE TOUT DÉPANNAGE.
LE CHÂSSIS DE CE RÉCEPTEUR EST DIRECTEMENT RACCORDÉ À L'ALIMENTATION SECTEUR.

ATTENTION AUX COMPOSANTS RELATIFS À LA SÉCURITÉ!!

LES COMPOSANTS IDENTIFIÉS PAR UNE TRAME ET PAR UNE MARQUE  SUR LES VUES EXPLOSÉES ET LES LISTES DE PIÈCES SONT D'UNE IMPORTANCE CRITIQUE PUR LA SÉCURITÉ DU FONCTIONNEMENT. NE LES REMPLACER QUE PAR DES COMPOSANTS SONY DONT LE NUMÉRO DE PIÈCE EST INDIQUÉ DANS LE PRÉSENT MANUEL OU DANS DES SUPPLÉMENTS PUBLIÉS PAR SONY.

SECTION 1 GENERAL

The operating instructions mentioned here are partial abstracts from the Operating Instruction Manual. The page numbers of the Operating Instruction Manual remain as in the manual.

Step 1 Preparation

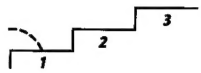

1 Check the supplied accessories

When you've taken everything out of the carton, check that you have these items:

- Remote Commander RM-831
- Scroll Commander RM-860
- Two IEC designation R6 batteries
- Two detachable speakers
- Woofer

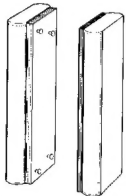
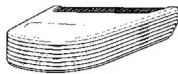

2 Insert the battery into the Remote Commanders

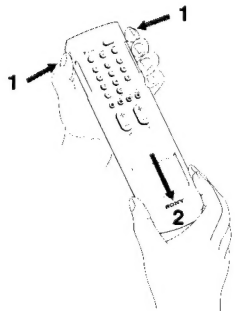

Remove the cover.

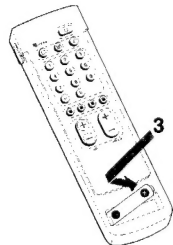

Check the correct polarities.

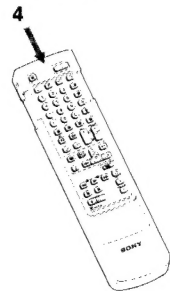

Refit the outside cover making sure that the Full-Function side is visible to use the menu in Step 3.



Check the correct polarities.

Step 2 Connection

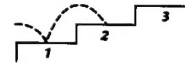

1 Connect the speakers and the woofer

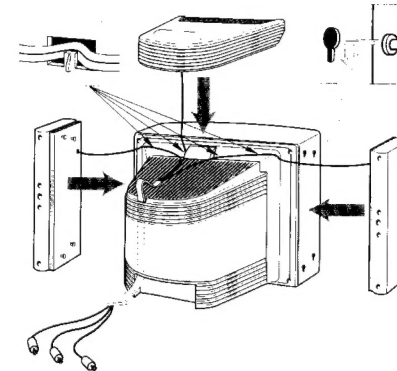

Hook the two side speakers (L = left, R = right) into the openings on both sides of the TV. Clip the cables of the speakers into the hooks on top of the set and pass the cables down through the opening at the rear of the TV (see above illustration).

Plug the connectors of the speaker cords into the rear of the TV (L/G/S/I for the left box, R/D/D/D for the right box with the longer cable).

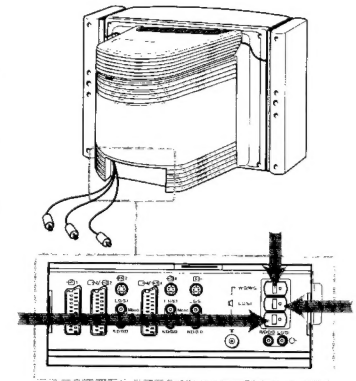

Pass the cable of the woofer down through the opening at the rear of the set. Place the woofer on top of the TV and plug the connector of the woofer into the rear of the TV (W/G/W/G).

Safety Information: If the side speakers are not connected to the set, make sure to close the side openings using the supplied plugs. Never insert any objects through the openings.

2 Connect the aerial

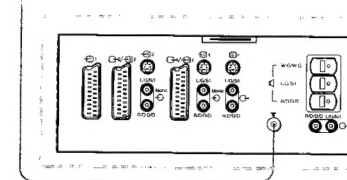

Fit an IEC aerial connector attached to 75-ohm coaxial cable (not supplied) to the 'Aerial' socket at the rear of the TV.

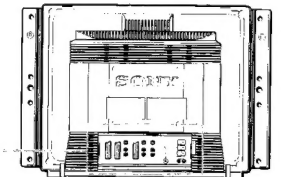

Step 3 Tuning in to TV Stations

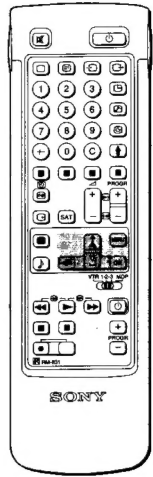
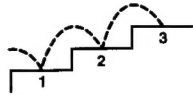

Once you have set up the TV, you can choose the language of the menu. Then you should preset the channels (up to 100 channels) by choosing either the automatic or manual method.

The automatic method is easier if you want to preset all receivable channels at once. Use the manual method if you only have a few channels and want to preset channels one by one. The manual method is also convenient for allocating programme numbers to various video input sources.

Before you begin

- Check that the Full-Function side of the Remote Commander is visible.
- Locate Menu operation buttons on the Remote Commander. They are shaded in the illustration at the left.

Easy Menu operation using the Scroll Commander

In addition to our double-sided Remote Commander, your TV set is supplied with an extra Remote Commander. The »Scroll Commander« works with a roller for convenient, fast-access operation of the menu functions. Move the roller upwards to move the cursor upwards, move the roller downwards to move the cursor downwards, press the roller to confirm a selection. The other buttons on this commander have the same functions as the respective buttons on the double-sided Remote Commander.

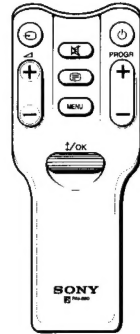

1 Choose a language

- 1 Depress on the TV. The TV will switch on. If the standby indicator on the TV is lit, press or a number button on the Remote Commander.
- 2 Press the MENU button. The LANGUAGE menu appears. (See Fig. 1)
- 3 Select the language you want with $\Delta+$ or $\nabla-$ and press OK.



Fig. 1

To go back to main menu: Keep pressing \leftarrow .

To go back to the normal TV picture: Press MENU. Normal TV picture will be restored after one minute if menu functions are not selected.

Note on the Demo function: If you choose Demo in the Installation menu, you can see a sequential demonstration of the menu functions. Press MENU to stop the function.

2 Display the Menu

Press the MENU button twice. The main menu appears. (See Fig. 2) Using $\Delta+$ or $\nabla-$ select the symbol and press OK. Now, choose one of the methods described overleaf: »Preset Channels Automatically«

or
»Preset Channels Manually«.

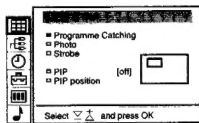

Fig. 2

With this method, you can preset all receivable channels at once.

To stop automatic channel presetting: Press \leftarrow on the Remote Commander.

Notes:
• After presetting the channels automatically, you can check which channels are stored on which programme positions. For details, see »Displaying the Programme Table« on page 46.

• You can sort the programme positions to have them appear on screen in the order you like. For details, see »Sorting Programme Positions« on page 41.

Programme names are automatically taken from Teletext if available. If not, please refer to page 43 »Captioning a Station name« for more information.

Use this method if there are only a few channels in your area to preset or if you want to preset channels one by one. You may also allocate programme numbers to various video input sources.

If you have made a mistake: Press \leftarrow to go back to the previous position. To go back to main menu: Keep pressing \leftarrow . To go back to the normal TV picture: Press MENU.

3 Preset channels automatically

- 1 Select the symbol for »Preset« with $\Delta+$ or $\nabla-$ and press OK. The PRESET menu appears. (See Fig. 3.)
- 2 Select »Auto Programme« with $\Delta+$ or $\nabla-$ and press OK. The AUTO PROGRAMME menu appears. (See Fig. 4.)
- 3 Press OK. Select if necessary the TV broadcast system (B/G for Western European or D/K for Eastern European countries) with $\Delta+$ or $\nabla-$ and press OK. The first element of the »PROG« number will be highlighted.
- 4 Select the programme (number button) from which you want to start presetting. Select the first element of the double-digit number with $\Delta+$ or $\nabla-$ or the number buttons (e.g. For »04«, select »0« here) and press OK. The second element of »PROG« will be highlighted.
- 5 Select the second element of the double-digit number with $\Delta+$ or $\nabla-$ or the number buttons (e.g. For »04«, select »4« here) (See Fig. 5.) and press OK.
- 6 Select »C« or »S« with $\Delta+$ or $\nabla-$ and press OK. The automatic channel presetting starts. When presetting is finished, the preset menu reappears. All available channels are now stored on successive number buttons. Press MENU to restore normal TV picture.

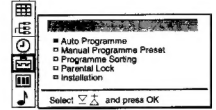

Fig. 3

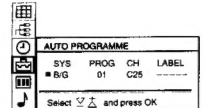

Fig. 4

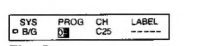

Fig. 5

3 Preset channels manually

- 1 Select the symbol for »Preset« with $\Delta+$ or $\nabla-$ and press OK. The PRESET menu appears. (See Fig. 6.)
- 2 Select »Manual Programme Preset« with $\Delta+$ or $\nabla-$ and press OK. The MANUAL PROGRAMME PRESET menu appears. (See Fig. 7.)

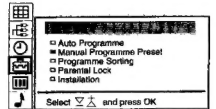

Fig. 6

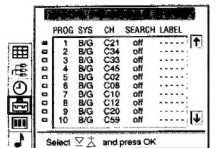

Fig. 7

To tune in a channel by frequency:
After selecting F in step 6, enter three digits using the number buttons. Press OK.

- 3 Using $\Delta+$ or $\nabla-$, select the programme position (number button) to which you want to preset a channel, and press OK.
- 4 Select, if necessary the TV broadcast system or a video input source (EXT) with $\Delta+$ or $\nabla-$.
- 5 Then press OK. The CH position will be highlighted. (See Fig. 8.)
- 6 Using $\Delta+$ or $\nabla-$, select C (to preset a regular channel), S (cable channel) or F (to tune in by frequency) and press OK. The first element of the »CH« number will be highlighted. If you have selected EXT in step 5, select the video input source with $\Delta+$ or $\nabla-$. (See Fig. 9.)

There are two ways to preset channels. If you know the channel number, go to step »7-Manual«,

or

if you don't know the channel number, go to step »7- Search«.

7 Manual

- a Select the first element of the »CH« number with $\Delta+$ or $\nabla-$ or the number buttons and press OK. The second element of the »CH« number will be highlighted.
- b Select the second element of the number with $\Delta+$ or $\nabla-$ or the number buttons. The selected number appears. (See Fig. 10.)
- c Press OK. The »SEARCH« position is highlighted and the selected channel is now stored. (See Fig. 11.)
- d Press OK until the cursor appears by the next programme position.
- e Repeat steps 3 to 7 to preset other channels.

7 Search

- a Press OK repeatedly until the colour of the SEARCH position changes.
- b Start searching for the channel with $\Delta+$ (up) or $\nabla-$ (down). The CH position changes colour. (See Fig. 12.) The CH number starts counting up or downwards. When a channel is found, it stops. (See Fig. 13.)
- c Press OK if you want to store this channel. If not, press $\Delta+$ or $\nabla-$ to continue channel searching.
- d Press OK until the cursor appears by the next programme position.
- e Repeat steps 3 to 7 to preset other channels.

If you have made a mistake:
Press \leftarrow to go back to the previous position.
To go back to main menu:
Keep pressing \leftarrow .
To go back to the normal TV picture:
Press MENU.

02 B/G C 01 off -----

Fig. 8

03 EXT AV1 -----

Fig. 9

02 B/G C 01 off -----

Fig. 10

02 B/G C 35 off -----

Fig. 11

02 B/G C 35 off -----

Fig. 12

02 B/G C 50 ▲▼ -----

Fig. 13

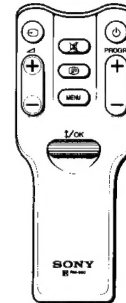

PROGRAMME SORTING

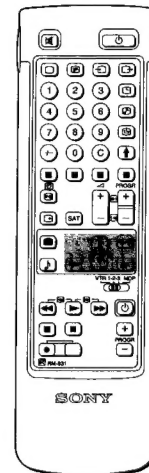

PROGRAMME SORTING

For higher programme positions:

The display scrolls automatically.
If you have made a mistake:
Press \leftarrow to go back to the previous position.

To go back to main menu:
Keep pressing \leftarrow .
To go back to the normal TV picture:
Press MENU.

Additional Presetting Functions

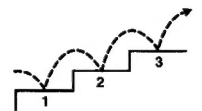

This section shows you additional presetting functions such as sorting or skipping programme positions, captioning a station name, manual fine-tuning, and using the parental lock.

Before you begin

- Check that the Full Function side of the Remote Commander is visible
- Locate the Menu operation buttons.

Sorting Programme Positions

With this function, you can sort the programme positions to a preferable order.

- 1 Press MENU to display the main menu.
- 2 Select the symbol  for »Preset« with $\Delta+$ or $\nabla-$ and press OK. The PRESET menu appears.
- 3 Select »Programme Sorting« with $\Delta+$ or $\nabla-$ and press OK. The PROGRAMME SORTING menu appears. (See Fig. 14.)
- 4 Using $\Delta+$ or $\nabla-$ select the programme position which you want to move to another and press OK. The colour of the selected position changes. (See Fig. 15.)
- 5 Using $\Delta+$ or $\nabla-$ select the programme position to which you want to move the channel of the programme position selected in step 4 and press OK. Now the programme positions have been sorted. (See Fig. 16.)
- 6 Repeat steps 4 and 5 to sort other programme positions.

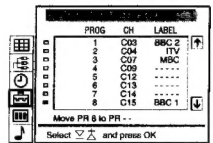

Fig. 14

8 C15 BBC 1

Fig. 15

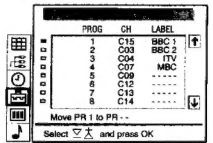



Fig. 16

How to adjust the Picture Rotation

If due to the earth magnetism the picture »slants«, you can use the function »Picture Rotation« to readjust the picture.

- 1 Press MENU to display the main menu.
- 2 Select the symbol  for »Preset« with $\Delta+$ or $\nabla-$ and press OK. The PRESET menu appears.
- 3 Select »Installation« with $\Delta+$ or $\nabla-$ and press OK. The INSTALLATION menu appears.
- 4 Select »Picture Rotation« with $\Delta+$ or $\nabla-$ and press OK. The PICTURE ROTATION menu appears. (See Fig. 17.)
- 5 Press OK. Adjust the picture rotation with $\Delta+$ or $\nabla-$ until you have an upright picture. As you press the cursor buttons, the range changes from - 4 to + 4.
- 6 Press OK to store the adjustment.

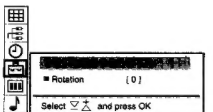



Fig. 17

Using »Further Programme Preset«

Using the menu »Further Programme Preset« you can

- individually adjust and store the volume level of each channel (Volume offset).
- in case of a strong sound signal (distorted sound), attenuate the sound signal for each programme position.
- use the manual fine tuning to obtain a better picture reception, if the picture is distorted. Normally the AFT (automatic fine tuning) is operating.

- Press MENU to display the main menu.
- Select the symbol  for »Preset« with Δ + or ∇ - and press OK. The PRESET menu appears.
- Select »Installation« with Δ + or ∇ - and press OK. The INSTALLATION menu appears.
- Select »Further Programme Preset« with Δ + or ∇ - and press OK. The FURTHER PROGRAMME PRESET menu appears (See Fig. 18).

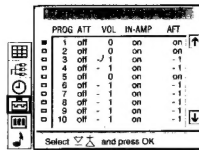

Fig. 18

- Using Δ + or ∇ - select the desired programme position and press OK once to select a) VOL (Volume offset), twice to select b) »IN-AMP« (Input Amplifier) or three times to select c) AFT (Automatic Fine Tuning). The selected item changes colour.

To adjust or change:

a) Volume offset (VOL)

Using Δ + or ∇ - you can adjust the volume level for the selected programme position within a range from -7 to +7. Press OK to store the volume level. Repeat step 5 to set the volume level for other programme positions.

b) IN-AMP (input amplifier)

Using Δ + or ∇ - select »Off« for the selected programme position. Press OK to confirm the selection. Repeat step 5 to switch off the input amplifier for other programme positions.

c) AFT

Using Δ + or ∇ - you can fine-tune the channel within a range from -15 to +15. Press OK to store the fine-tuned level. Repeat step 5 to fine-tune the other channels.

- Press MENU to return to the normal TV mode.

To reactivate AFT (Automatic Fine Tuning)
Repeat from the beginning and select »ON« in step 5.

MANUAL PROGRAMME PRESET

Skiping Programme Positions

You can skip unused programme positions when selecting programmes with the PROGR +/- buttons. However, the skipped programmes may still be called up when you use the number buttons.

- Press MENU to display the main menu.
- Select the symbol  for »Preset« with Δ + or ∇ - and press OK. The PRESET menu appears.
- Select »Manual Programme Preset« with Δ + or ∇ - and press OK. The MANUAL PROGRAMME PRESET menu appears. (See Fig. 19.)
- Using Δ + or ∇ -, select the programme position which you want to skip and press OK. The »SYS« position changes colour.
- Press Δ + or ∇ - until »---« appears in the SYSTEM position. (See Fig. 20.)
- Press OK. (See Fig. 21.) When you select programmes using the PROGR +/- buttons, the programme position will be skipped.
- Repeat steps 4 to 6 to skip other programme positions.

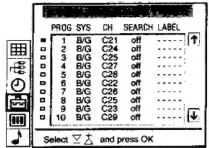

Fig. 19

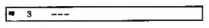

Fig. 20



Fig. 21

MANUAL PROGRAMME PRESET

Captioning a Station Name

Programme names are usually automatically taken from Teletext if available. You can also »name« a channel or an input video source using up to five characters (letters or numbers) to be displayed on the TV screen (e.g. BBC1). Using this function, you can easily identify which channel or video source you are watching.

- Press MENU to display the main menu.
- Select the symbol  for »Preset« with Δ + or ∇ - and press OK. The PRESET menu appears.
- Select »Manual Programme Preset« with Δ + or ∇ - and press OK. The MANUAL PROGRAMME PRESET menu appears. (See Fig. 22.)
- Using Δ + or ∇ -, select the programme position you want to caption and press OK repeatedly until the first element of the LABEL position is highlighted.
- Select a letter or number with Δ + or ∇ - and press OK. The next element will be highlighted. Select other characters in the same way. If you want to leave an element blank, select - and press OK. (See Fig. 23.)
- After selecting all the characters, press OK repeatedly until the cursor appears by the next programme position (at the left margin). Now the caption you chose is stored. (See Fig. 24.)
- Repeat steps 5 and 6 to caption names for other channels.

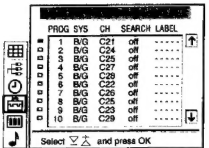

Fig. 22



Fig. 23



Fig. 24

If you have made a mistake:
Press \leftarrow to go back to the previous position.

To go back to main menu:
Keep pressing \leftarrow .



To go back to the normal TV picture:
Press MENU.

PARENTAL LOCK

If you try to select a programme that has been blocked: The message »-LOCKED« appears on the blank TV screen.

Parental Lock

You can prevent undesirable broadcasts from appearing on the screen. We suggest you use this function to prevent children from watching programmes which you consider unsuitable.

- 1 Press MENU to display the main menu.
- 2 Select the symbol  for »Preset« with $\Delta+$ or $\nabla-$ and press OK. The PRESET menu appears.
- 3 Select »Parental Lock« with $\Delta+$ or $\nabla-$ and press OK. The PARENTAL LOCK menu appears. (See Fig. 25.)
- 4 Using $\Delta+$ or $\nabla-$, select the programme position you want to block and press OK. The symbol  appears in front of the programme number indicating that this programme is now blocked. (See Fig. 26.)
- 5 Repeat step 4 to block other programme positions.

Cancelling blocking

- 1 On the PARENTAL LOCK menu, select the programme position you want to unblock with $\Delta+$ or $\nabla-$.
- 2 Press OK. The symbol  disappears indicating that the blocking has been cancelled.

Tuning in a Channel Temporarily

You can tune in a channel temporarily, even when it has not been preset. Use the buttons on the Full-Function side of the Remote Commander.

- 1 Press C on the Remote Commander. For cable channels, press C twice. The indication »C« (»S« for cable channels) appears on the screen.
- 2 Enter the double-digit channel number using the number buttons (e.g. for channel 4, first press 0, then 4). The channel appears. However, the channel will not be stored.

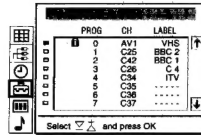

PROG	CH	LABEL
0	AV1	VHS
1	C25	BBC 2
2	C32	BBC 1
3	C36	C 4
4	C34	TV
5	C35
6	C38
7	C37

Fig. 25

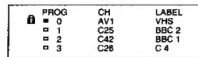



PROG	CH	LABEL
 0	AV1	VHS
1	C25	BBC 2
2	C42	BBC 1
3	C28	C 4

Fig. 26

Operating Instructions

Watching the TV

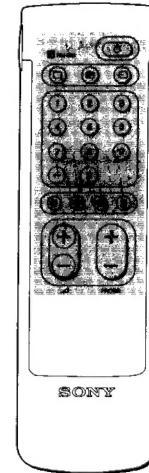

If no picture appears when you depress  on the TV and if the standby indicator on the TV is lit, the TV is in standby mode. Press  or one of the number buttons to switch it on.

This section explains the basic functions you use while watching TV. Most of the operations can be done using the simple side of the Remote Commander.

Switching the TV on and off

Switching on

Depress  on the TV.

Switching off temporarily

Press  on the Remote Commander.

The TV enters standby mode and the standby indicator on the front of the TV lights up.

To switch on again

Press , PROG \pm , or one of the number buttons on the Remote Commander.

Switching off completely

Depress  on the TV.

Selecting TV Programmes

Press PROG \pm or the number buttons.

To select a double-digit number





Press \leftarrow , then the number.

For example, if you want to choose 23, press \leftarrow , 2 and 3.

Adjusting the Volume

Press \triangle/\pm .

Operating the TV Using the Buttons on the TV

- With the buttons on the TV, you can select programmes, adjust the volume, and select video input sources. Press P \rightarrow   button repeatedly until the programme number,  (for volume), or  (for video input picture) appears. Then adjust with the \pm buttons.
- Press \leftarrow buttons to switch on the TV from the standby mode.
- Press \leftarrow simultaneously to reset picture and sound controls to the factory preset level (RESET function).

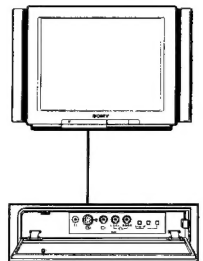
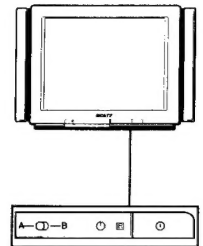

For details of the teletext operation, refer to page 52.

For details of the video input picture, refer to page 55.

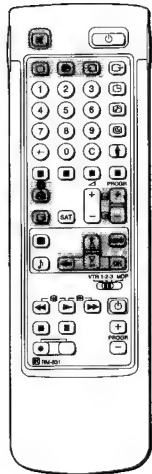

Watching Teletext or Video Input

Watching teletext

- Press **[RECALL]** to view the teletext.
- Press three number buttons to select a page.
- Press one of the coloured buttons for fasttext operation.
- Press **[PAGE +]** or **[PAGE -]** for the next or preceding page.
- To go back to the normal TV picture, press **[STOP]**.

Watching a video input picture

Press **[VIDEO]** repeatedly until the desired video input appears. To go back to the normal TV picture, press **[STOP]**.

More Convenient Functions

Use the Full-Function side of the Remote Commander.

Displaying the on screen indications

- Press **[ON SCREEN INDICATIONS]** once to display all the indications. They will disappear after some seconds.
- Press **[ON SCREEN INDICATIONS]** twice to have the programme number and label stay on screen. Press twice again to make indications disappear.

Muting the sound.

Press **[MUTE]**.

To resume normal sound, press **[MUTE]** again.

Displaying the time

Press **[TIME]**. This function is available only when teletext is broadcast.

To make the time display disappear, press **[TIME]** again.

Displaying the Programme Table

Press **[OK]**. A Programme Table will be displayed on the right side of the TV screen (See Fig.27).

Selecting TV programmes

Press **[PROGR +/-]** or select the desired programme position using **[Δ+]** or **[∇-]** and press **[OK]**.

To make the Programme Table disappear, press **[MENU]**.

1	SBC	[↑]
2	SAT	[↑]
3	TV5	[↑]
4	CBC	[↑]
5	C15	[↑]
6	RIL	[↑]
7	SKY	[↑]
8	S34	[↑]
9	AV1	[↑]
10	MTV	[↑]

Fig. 27

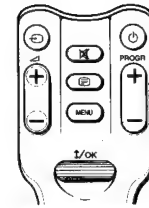

PICTURE CONTROL

SOUND CONTROL

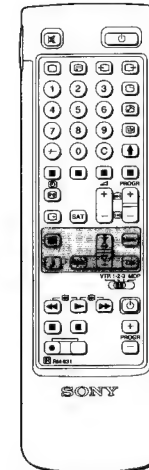

If you have made a mistake:

Press **[←]** to go back to the previous position.

To go back to the main menu: Keep pressing **[←]**.

To go back to the normal TV picture: Press **[MENU]**.

Note on LINE OUT:

The audio level and the dual sound mode output from the **[G]** jack on the rear correspond to the HEADPHONES VOLUME and DUAL SOUND settings.

When watching a video input source with stereo sound:

You can select DUAL SOUND to change the sound.

Adjusting and Setting the TV Using the Menu

Adjusting the Picture and Sound

Although the picture and sound are adjusted at the factory, you can adjust them to suit your own taste. In addition, you can reduce the picture noise. You can also select dual sound (bilingual) programmes when available, adjust the sound for listening with the headphones (🎧).

- 1 Press **[PICTURE]** (for picture) or **[SOUND]** (for sound) on the Remote Commander.

or

Press **[MENU]** and select on the screen the symbol **[PICTURE]** for Picture Control or **[SOUND]** for Sound Control, then press **[OK]**. The PICTURE CONTROL or SOUND CONTROL menu appears. (See Fig. 28 or Fig. 29)

- 2 Using **[Δ+]** or **[∇-]**, select the item you want to adjust and press **[OK]**. The selected item changes colour. (See Fig. 30)
- 3 Adjust the setting with **[Δ+]** or **[∇-]** and press **[OK]**. The cursor appears beside the next item (at the left margin). (See Fig. 31)
- 4 Repeat steps 2 and 3 to adjust other items.



Fig. 28

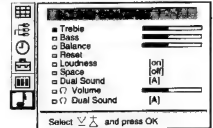

Fig. 29



Fig. 30



Fig. 31

Effect of each control

PICTURE CONTROL	Effect
Contrast	Less — — More
Brightness	Darker — — Brighter
Colour	Less — — More
Hue (only for NTSC)	Greenish — — Reddish
Sharpness	Softer — — Sharper
Reset	Resets picture to the factory preset levels.
Screen Mode	Auto (automatic selection of 16:9 broadcasts decoded in 4:3) → 4:3 Normal → 16:9 Wide screen effect
Noise Reduction	Off: Normal on: Reduction of picture noise in case of weak signals
Digital Mode	I: Normal II: LFR (Line Flicker Reduction) off

SOUND CONTROL	Effect
Treble	Less — — More
Bass	Less — — More
Balance	More left — — More right
Reset	Resets sound to the factory preset levels.
Loudness	off : Normal on : When listening to low volume sound.
Space	off : Normal on : Obtain acoustic sound effect.
Dual Sound	A : channel 1 B : channel 2 stereo mono The selected mode of the A-CD-B indicator on the TV lights up.
Headphones:	
🎧 Volume	Less — — More
🎧 Dual Sound	A: channel 1 B: channel 2 stereo mono PIP (if PIP is switched on you can select the PIP sound for the headphones)

PIP (Picture in Picture)

TIMER

To switch off the timer:
Select »OFF« in step 3.

To check the remaining time:
Press \square .

To go back to the normal TV picture:
Press MENU.

Using the Sleep Timer

You can select a time period after which the TV automatically switches into standby mode.

- Using Δ + or ∇ - select the symbol \odot for »Timer« and press OK. The TIMER menu appears (see Fig. 32).
- Press OK.
The time period option changes colour.
- Select the time period with Δ + or ∇ -.
The time period (in minutes) changes as follows:
OFF \rightarrow 10 \rightarrow 20 \rightarrow 30 \rightarrow 40 \rightarrow 50 \rightarrow 60 \rightarrow 70 \rightarrow 80 \rightarrow 90
 \uparrow
- After selecting the time period, press OK.
The cursor moves back to the left margin and the timer starts counting.
One minute before the TV switches into standby mode, a message is displayed on the screen.

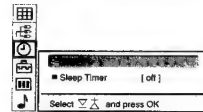
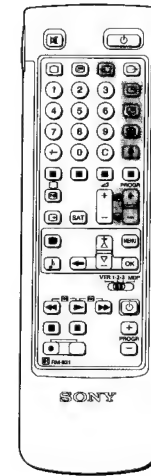
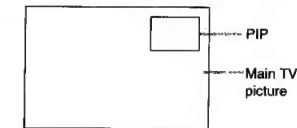

Fig. 32



Notes:
• RGB input source cannot be displayed in PIP.

With this function you can display a »PIP screen« (small picture) within the main TV picture. In this way you can watch or monitor the video output from any connected equipment (for example from a VTR) while watching TV or vice versa. For information about connection of other equipment, refer to page 54.



Switching PIP on and off

Press \square .

The PIP screen will be displayed. The PIP picture will come from the source chosen when the TV was last used.

To switch PIP off

Press \square again.

Selecting a PIP source

Press \uparrow .

The symbol \uparrow will be displayed at the bottom, left-hand corner of the screen.

Press \odot repeatedly until the desired source is indicated (e.g. TV, AV1, AV2, YC2, AV3, YC3, AV4, YC4).

Note

If no video source has been connected, the PIP picture will be noisy.

Swapping screens

Press \square .

The main screen will switch the picture with the PIP screen.

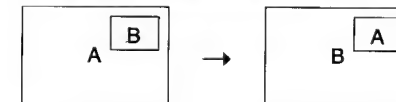

Note

If a TV programme is on the PIP screen and a video source on the main picture, and you want to change channels, first press \uparrow and then the programme buttons or PROGR +/-.

Changing the position of the PIP

Press \square repeatedly to change the position of the PIP screen within the main screen. There are four different positions available.

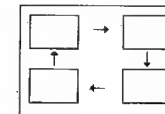

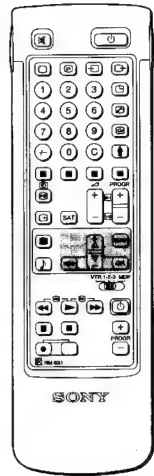

Operating Multi PIP using the Menu

Using the »Multi PIP« Menu you have the possibility to operate the PIP mode, scan 9 successive TV channels on the screen (Programme Catching), display 8 successive freeze pictures (Photo mode) or reproduce the main picture image by image (strobe function).

- 1 Press MENU to display the main menu.
 - 2 Select the symbol  for »MULTI PIP« with Δ + or ∇ - and press OK. The MULTI PIP menu appears (See Fig. 33).
- a) **Programme Catching**
Using Δ + or ∇ - select »Programme Catching« and press OK. Now a scan of 9 successive programmes (8 still pictures, 1 live picture where the cursor is positioned) is displayed on the TV screen starting from the programme tuned in. Using Δ + or ∇ - you can move the cursor and update the still pictures. The programme scanning starts again if you select the programme position lower or higher than the 9 displayed ones (See Fig. 34).
- To select a Programme using Programme Catching**
Using Δ + or ∇ - select the desired programme position and press OK. Now the selected programme is displayed and you are back in the normal TV mode.
- b) **Photo Mode**
Using Δ + or ∇ - select »Photo« and press OK. Now the main picture is displayed as a succession of 8 still pictures and a 9th picture which will be live (See Fig. 35). Using Δ + or ∇ - the photo mode starts again. Press OK to return to the normal TV mode.
- c) **Strobe mode**
Using Δ + or ∇ - select »Strobe« and press OK. Now the TV picture is displayed image by image, which gives it the effect of slow motion (See Fig. 36). Using Δ + or ∇ - select the speed of the motion (3 different speeds are available). Press OK to return to the normal TV mode.
- d) **Switching PIP on and off**
Using Δ + or ∇ - select »PIP« and press OK. Using Δ + or ∇ - select »ON« to display the PIP screen and »OFF« to switch it off and press OK.
- e) **Changing the position of the PIP**
Using Δ + or ∇ - select »PIP position« and press OK. Using Δ + or ∇ - repeatedly to change the position of the PIP screen and press OK.

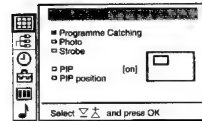

Fig. 33

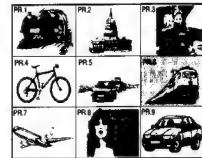

Fig. 34

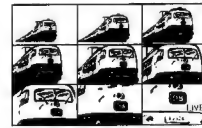

Fig. 35

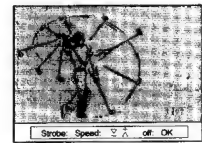
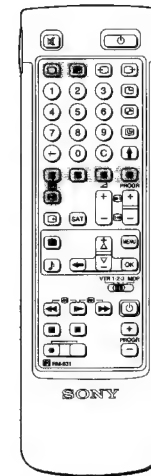
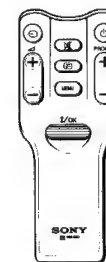

Fig. 36



Notes:
• Teletext errors may occur if the broadcasting signals are weak.



Note:
Fastext operation is only possible, if the TV station broadcasts Fastext signals.

TV stations broadcast an information service called Teletext via the TV channels. Teletext service allows you to receive various information pages such as weather reports or news at any time you want. For advanced teletext operation, use the buttons on the Full-Function side of the Remote Commander.

Direct Access Functions

Switching Teletext on and off

- 1 Select the TV channel which carries the teletext broadcast you want to watch.
- 2 Press  to switch on teletext. A teletext page will be displayed (usually the index page). If there is no teletext broadcast, »No text available« is displayed on the information line at the top of the screen.

To switch teletext off
Press .

Selecting a teletext page

With direct page selection



Use the number buttons to input the three digits of the chosen page number. If you have made a mistake, type in any three digits. Then re-enter the correct page number.

With page-catching



- 1 Select a teletext page with a page overview (e.g. index page).
- 2 Press OK. Using Δ + or ∇ -, select the desired page. »Page Catching« will be displayed on the information line. Press OK. The requested page will appear in a few seconds.

Press  to resume normal teletext reception.



Accessing the next or preceding page

Press  (PAGE +) or  (PAGE -). The next or preceding page appears.

Superimposing the teletext display on the TV programme

- Press  once in teletext mode or twice in TV mode.
- Press  again to resume normal teletext reception.

Preventing a teletext page from being updated

- Press  (HOLD). The HOLD symbol »H« is displayed on the information line.
- Press  to resume normal teletext reception.

Using Fastext

With Fastext you can access pages with one key stroke. When a Fastext page is broadcast, a colour-coded menu will appear at the bottom of the screen. The colours of this menu correspond to the red, green, yellow and blue buttons on the Remote Commander.

Press the corresponding coloured button on the Remote Commander which corresponds to the colour-coded menu. The page will be displayed after some seconds.

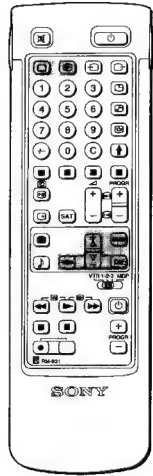

Note:
Some of the features may not be available depending on the Teletext service.



To cancel the request:
Select »OFF« for the TIME PAGE setting.

Using the Teletext Menu

This TV is provided with a menu-guided teletext system. When teletext is switched on, you can use the menu buttons to operate the teletext menu. Select the teletext menu functions in the following way:

- 1 Press MENU. The menu will be superimposed on the teletext display. (See Fig. 37)
- 2 Using $\Delta+$ or $\nabla-$, select the teletext function you want and press OK. (See Fig. 38)

USER PAGES/PRESET USER PAGES

See page 53 for information about presetting and operating the user pages.

INDEX

The index will give you an overview of the contents of the teletext and the page numbers.

TOP/BOTTOM/FULL

For convenient reading of a teletext page, you can enlarge the teletext display with the ability to scroll up and down the screen. After having selected the function, an information line Top/Bottom/Full will be displayed. (See Fig. 39).

Press $\Delta+$ for »Top« to enlarge the upper half. For »Bottom« keep pressing $\nabla-$, to enlarge the lower half. Press OK for »Full« to resume the normal size.
Press OK to resume normal teletext reception.

TEXT CLEAR

After having selected the function, you can watch a TV programme while waiting for a requested teletext page to be captured (The symbol changes colour) (See Fig. 40). Press OK to view the requested page.

SUBTITLES

Your teletext service will inform you if a TV programme is subtitled. After having selected the function the subtitles will be displayed.

REVEAL

Sometimes pages contain concealed information, such as answers to a quiz. The reveal option lets you disclose the information. After having selected the function, an information line »REVEAL ON/OFF« will be displayed. (See Fig. 41).

Using $\Delta+$ or $\nabla-$, select ON to reveal the information or OFF to conceal it again.
Press OK to resume normal teletext reception.

TIME PAGE

Your teletext service will inform you, if a time coded page is available. You may have a page (e.g. an alarm page) displayed at a certain time.

- 1 Press OK. Using $\Delta+$ or $\nabla-$ select ON and press OK.
- 2 To select the desired page, enter the three digits of the page number (e.g. 301) using the number buttons.
- 3 To select the time, enter four digits for the desired time (e.g. 1800) using the number buttons. Press MENU. The selected time is displayed at the top in the left-handed corner. At the requested time, the page will be displayed.
Press OK to resume normal teletext mode.

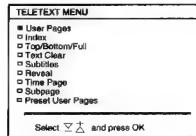

Fig. 37

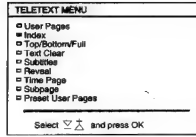

Fig. 38

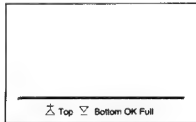

Fig. 39



Fig. 40

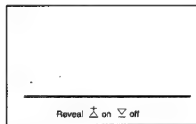

Fig. 41

To cancel the request:
Select »Subpage« and press OK.

If two broadcasting stations use the same Teletext:
You can preset one bank to 2 different programme positions.

SUBPAGE

You may want to select a particular teletext page from several subpages which are rotated automatically. After having selected the function, an information line will be displayed.

To select the desired subpage, enter four digits using PROG+/- or the number buttons. (e.g. enter 0002 for the second page of a sequence).

User Page Bank System

You can store up to 30 pages in the »Teletext page bank system«. In this way you have quick access to the pages you watch frequently.

Storing pages

There are 5 »banks« (A to E) for 5 teletext stations. In each bank you can store 6 preferred pages (P1 to P6).

- 1 Press OK (if Teletext is not on already) and MENU to show the TELETEXT MENU display.
- 2 Select PRESET USER PAGES with $\Delta+$ or $\nabla-$ and press OK.
- 3 Select the desired bank with $\Delta+$ or $\nabla-$ and press OK. The cursor will go to the first position (P1) of the preferred pages.
- 4 Input the three digits of your first preferred page with the number buttons and press OK.
The cursor will go to the second position.
- 5 Repeat step 4 for the other 5 page numbers you want to preset. If you do not want to preset all 6 page numbers available, press OK without inserting any number. After having finished the presetting press OK repeatedly until the cursor appears besides the next bank at the left margin.
- 6 Select Allocate Bank with $\Delta+$ or $\nabla-$ and press OK.
- 7 Select the programme position for which you have preset pages with $\Delta+$ or $\nabla-$ and press OK. (See Fig. 42)
- 8 Select the desired bank with $\Delta+$ or $\nabla-$ (Banks A to E are available) and press OK.
- 9 Repeat steps 3 to 8 for the other 4 banks available.

PRESET USER PAGES											
BANK	P1	P2	P3	P4	P5	P6					
A	300	256	456	234	200	178					
B	200	120	301	303	550	345					
C	100	220	300	444							
D	128	321	255								
E	400	238	240	118	127						
Allocate Bank											
PROG	LABEL	BANK	PROG	LABEL	BANK						
00	VHS	—	04	MTV	D						
01	BBC1	A	05	SKY	B						
02	BBC2	C	06	ITV	C						

Fig. 42

Displaying User Pages

- 1 Select MENU.
- 2 Select User Pages with $\Delta+$ or $\nabla-$ and press OK.
A table of the stored preferred pages will be displayed. (See Fig. 43)
- 3 Select the desired page with $\Delta+$ or $\nabla-$ and press OK. The page will be displayed after some seconds.

or

You can use the coloured buttons on the Remote Commander to have quick access to the first four User pages. Page 1 corresponds to the red button, P 2 to the green one, P 3 to the yellow one and P 4 to the blue button.

To select the desired page press the respective coloured button while you are in TV mode. Now the Page number of the teletext page will appear in white at the top in the left-handed corner of the TV screen. When the page number changes colour, the page is available. Press the coloured button again to display the page.

USER PAGES - BANK B					
■	PAGE 300				
■	PAGE 200				
■	PAGE 203				
■	PAGE 500				
■	PAGE 294				
■	PAGE 159				

Fig. 43

Connecting and Operating Optional Equipment

Connecting Optional Equipment

You can connect optional audio-video equipment to this TV such as VCRs, video disc players, and stereo systems.

To connect a VCR using the T terminal
Connect the aerial output of the VCR to the aerial terminal T of the TV.
We recommend that you tune in the signal to programme number »0«. For details see »Preset Channels Manually« on page 39.

If the picture or the sound is distorted
Move the VCR away from the TV.

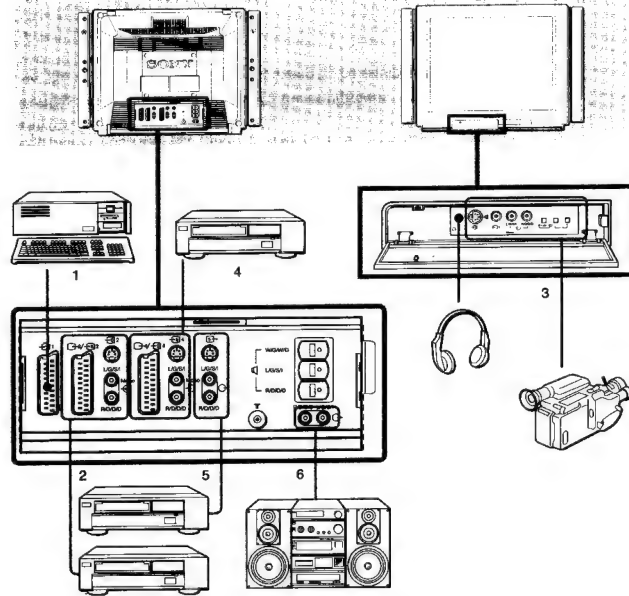

S video input (Y/C input)
Video signals may be separated into Y (luminance or brightness) and C (chrominance) signals. Separating the Y and C signals prevents them from interfering with one another, and therefore improves picture quality (especially luminance). This TV is equipped with 3 S Video input jacks through which these separated signals can be input directly.

When connecting a monaural VCR:
Connect only the white Y jack to both the TV and VCR.

Acceptable input signal	Available output signal
1 Normal audio/video and RGB signal	Video/audio from TV tuner
2 Normal audio/video and S video signal	Video/audio from selected source
3 Normal audio/video and S video signal	No outputs
4 Normal audio/video and S video signal	Video/audio displayed on TV screen (monitor out)
5 No inputs	S video/audio signal displayed on TV screen (monitor out)
6 No inputs	Audio signal (variable)

Selecting input with PROGR +/- or number buttons:
You can preset video input sources to the programme positions so that you can select them with PROGR +/- or number buttons. For details, see »Preset channels manually« on page 38.

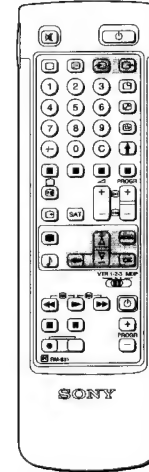

Selecting input and output

This section explains how to view the video input picture (of the video source connected to your TV), and how to select the output signal using direct access buttons or the menu system.

Selecting input

Press repeatedly to select the input source. The symbol of the selected input source will appear.

To go back to the normal TV picture

Press .

Input modes

Symbol	Input signal
	Audio/video input through the connector
	RGB input through the connector
	Audio/video input through the connector
	S video input through the or connector
	Audio/video input through and connectors at the front
	S video input through the connectors (4-pin connector) at the front
	Audio/video input through the connector
	S video input through the or connector (4-pin connector)

You can also select the input mode using the and buttons on the TV.

In this case, select first and then press the buttons to select the input.

Selecting the output

The connector outputs the source input from the other connectors.

You can also select the input mode using the and buttons on the TV. In this case, select first and then press the buttons to select the input.

Symbol	connector outputs
1	The audio/video signal from the connector
2	The audio/video signal from the connector
2	The audio/video signal from the connector
3	The audio/video signal from the connectors
3	The audio/video signal from the connectors
4	The audio/video signal from the connector
4	The audio/video signal from the connector
TV	The audio/video signal from the T aerial terminal

Using AV Preset

Using this function you can preset the desired input source (e.g. , RGB signal) to the respective AV input (AV 1). In this way a connected VTR will automatically switch to the RGB signal.

- Select the symbol for »Preset« with $\Delta+$ or $\nabla-$ and press OK.
- Select first »Installation«, then »AV Preset« with $\Delta+$ or $\nabla-$ and press OK. The AV PRESET menu appears (See Fig. 44).
- Select the desired AV input with $\Delta+$ or $\nabla-$ and press OK.

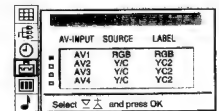
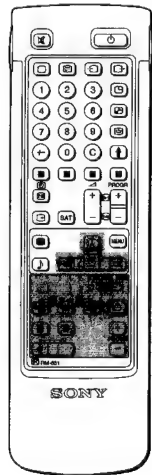

Fig. 44



When recording
When you use the ● (record) button, make sure to press this button and the one to the right of it simultaneously.

- Select the desired source with Δ+ or ∇- and press OK.
For the respective AV inputs you have the following possibilities:
AV 1 RGB or AV AV 3 YC3 or AV
AV 2 YC2 or AV AV 4 YC4 or AV
- If you want to name the AV input select »Label« using Δ+ or ∇- and press OK. Select a letter or a number with Δ+ or ∇- and press OK. The next element will be highlighted. Select other characters in the same way. If you want to leave an element blank, select - and press OK.
After having selected all the characters, press OK repeatedly until the cursor appears by the next AV input at the left margin.
- Repeat steps 3 to 5 for the other AV inputs.

Checking and selecting the input and output sources using the menu

You can display the menu to see which input sources are selected for the TV screen and PIP screen, and which output source is selected. You can also select them on the menu display.

- Select the symbol for »Video Connection« with Δ+ or ∇- and press OK. The VIDEO CONNECTION menu appears. (See Fig. 45)
You can see which source is selected for the TV and PIP input, and for the output. If you want to select the input and output on this menu, go on to the next step.
- Select TV Screen (input source for the TV screen), PIP (input source for the PIP screen), or output (output source) with Δ+ or ∇- and press OK. One of the source items changes colour.
- Select the desired source with Δ+ or ∇-.
For details about each source, see the table on page 55.
- Press OK.
The selected source is confirmed, and the cursor appears.
- Repeat steps 2 to 4 to select the source for other inputs or outputs.

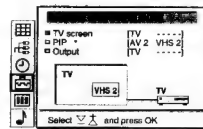

Fig. 45

Remote Control of Other Sony Equipment

You can use the TV Remote Commander to control other Sony remote-controlled video equipment. The buttons for video operation have been factory-set to control most of Sony video equipment, such as: Beta, 8mm or VHS VCRs or video disc players.

Tuning the Remote Commander to the equipment

- Set the VTR 1/2/3 MDP selector according to the equipment you want to control:
VTR 1: Beta VCR
VTR 2: 8mm VCR
VTR 3: VHS VCR
MDP: Video disc player
- Use the buttons indicated in the illustration to operate the additional equipment.

If your video equipment is furnished with a COMMAND MODE selector: set this selector to the same position as the VTR 1/2/3 MDP selector on the TV Remote Commander.

If the equipment does not have a certain function, the corresponding button on the Remote Commander will not operate.

For Your Information

Troubleshooting

Here are some simple solutions to problems which may affect the picture and sound.

Problem	Solution
No picture (screen is dark), no sound	<ul style="list-style-type: none"> Plug the TV in. Press ○ on the TV. (If ○ indicator is on, press □ or a programme number on the Remote Commander.) Check the aerial connection. Check if the selected video source is on. Turn the TV off for 3 or 4 seconds and then turn it on again using ○.
Poor or no picture (screen is dark), but good sound	<ul style="list-style-type: none"> Press ● to enter the PICTURE CONTROL menu and adjust »Brightness«, »Contrast« and »Colour«.
Poor picture quality when watching an RGB video source	<ul style="list-style-type: none"> Press - repeatedly to select ☺.
Good picture but poor or no sound	<ul style="list-style-type: none"> Press ▲ +. If ⚡ is displayed on the screen, press ⚡. Check the connections of the loudspeakers.
No colour for colour programmes	<ul style="list-style-type: none"> Press ● to enter the PICTURE CONTROL menu, select RESET, then press OK.
Remote Commander does not function.	<ul style="list-style-type: none"> Replace batteries.

If you continue to have problems, have your TV serviced by qualified personnel. Never open the casing yourself.

SECTION 2 DISASSEMBLY

2-1. REAR COVER REMOVAL

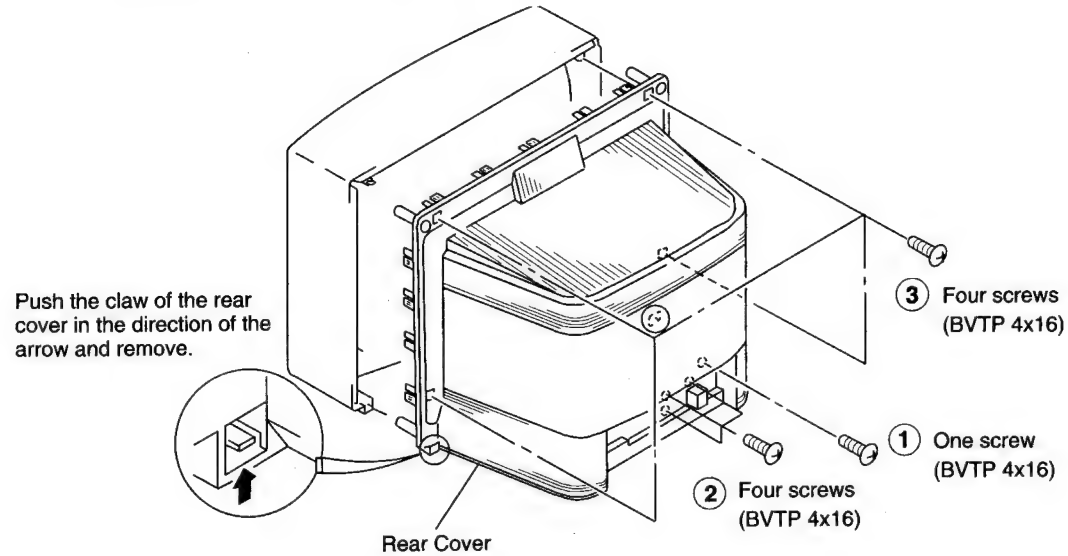

2-2. CHASSIS ASSY AND H BRACKET REMOVAL

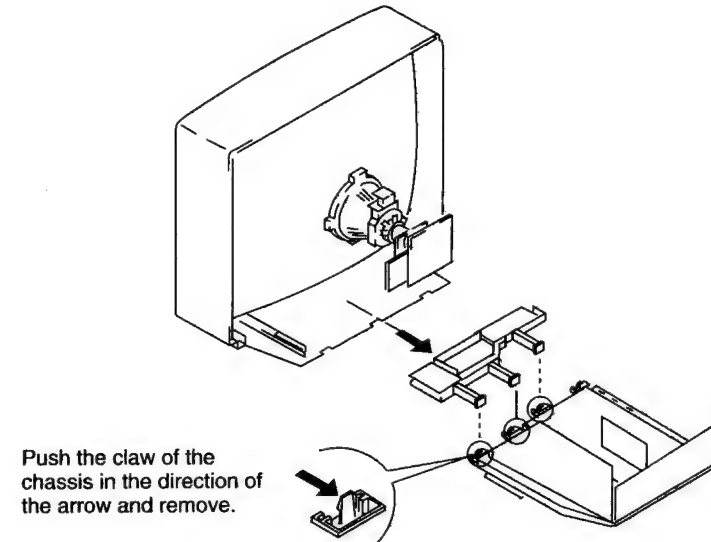

2-3. SERVICE POSITION

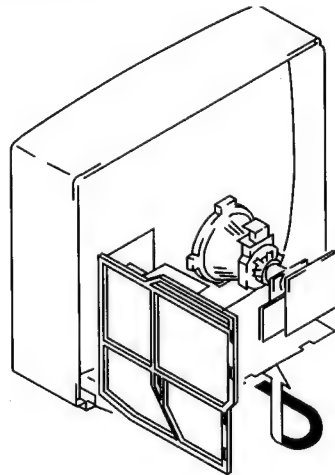

2-4. G AND J BOARD REMOVAL

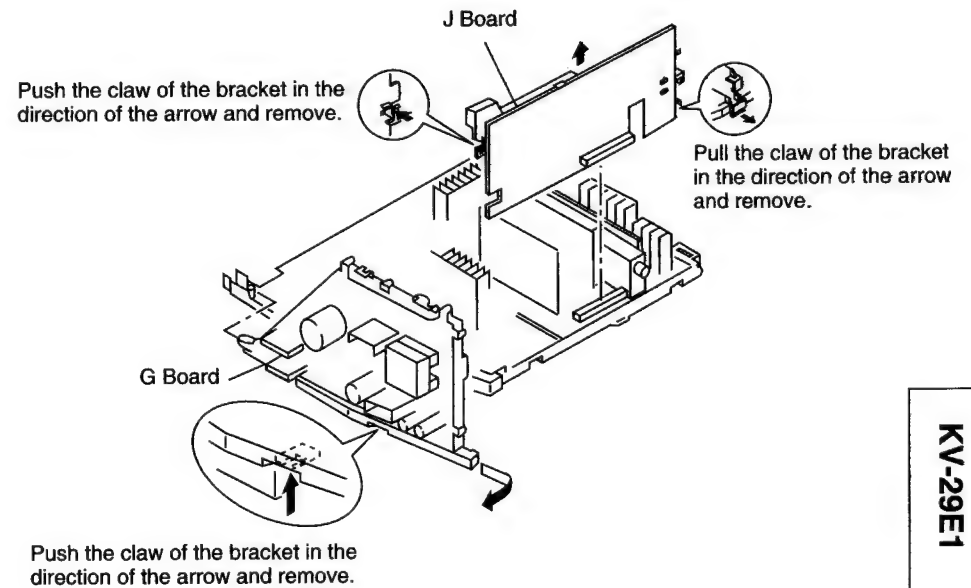

2-5. WIRE DRESSING

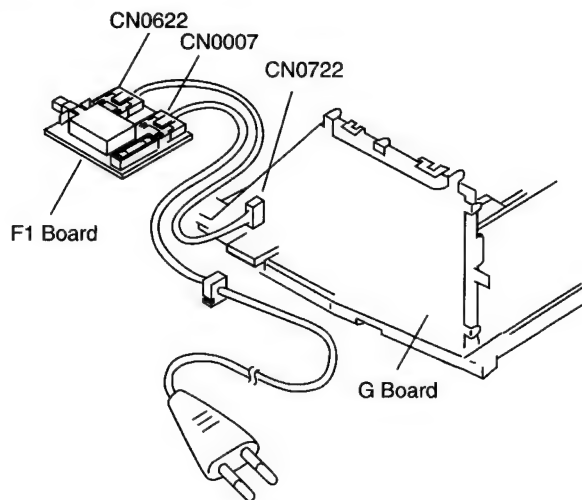

• REMOVAL OF ANODE-CAP

Note: Short circuit the anode of the picture tube and the anode cap to the metal chassis, CRT shield or carbon paint on the CRT, after removing the anode.

• REMOVING PROCEDURES.

-
- ① Turn up one side of the rubber cap in the direction indicated by the arrow ①
 - ② Using a thumb pull up the rubber cap firmly in the direction indicated by the arrow ②
 - ③ When one side of the rubber cap is separated from the anode button, the anode-cap can be removed by turning up the rubber cap and pulling it up in the direction of the arrow ③

• HOW TO HANDLE AN ANODE-CAP

- ① Don't damage the surface of anode-cap with sharp shaped material !
- ② Don't press the rubber hardly not to hurt inside of anode-caps !
A metal fitting called as shatter-hook terminal is built into the rubber.
- ③ Don't turn the foot of rubber over hardly !
The shatter-hook terminal will stick out or damage the rubber.

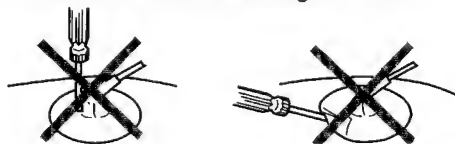

2-6. PICTURE TUBE REMOVAL

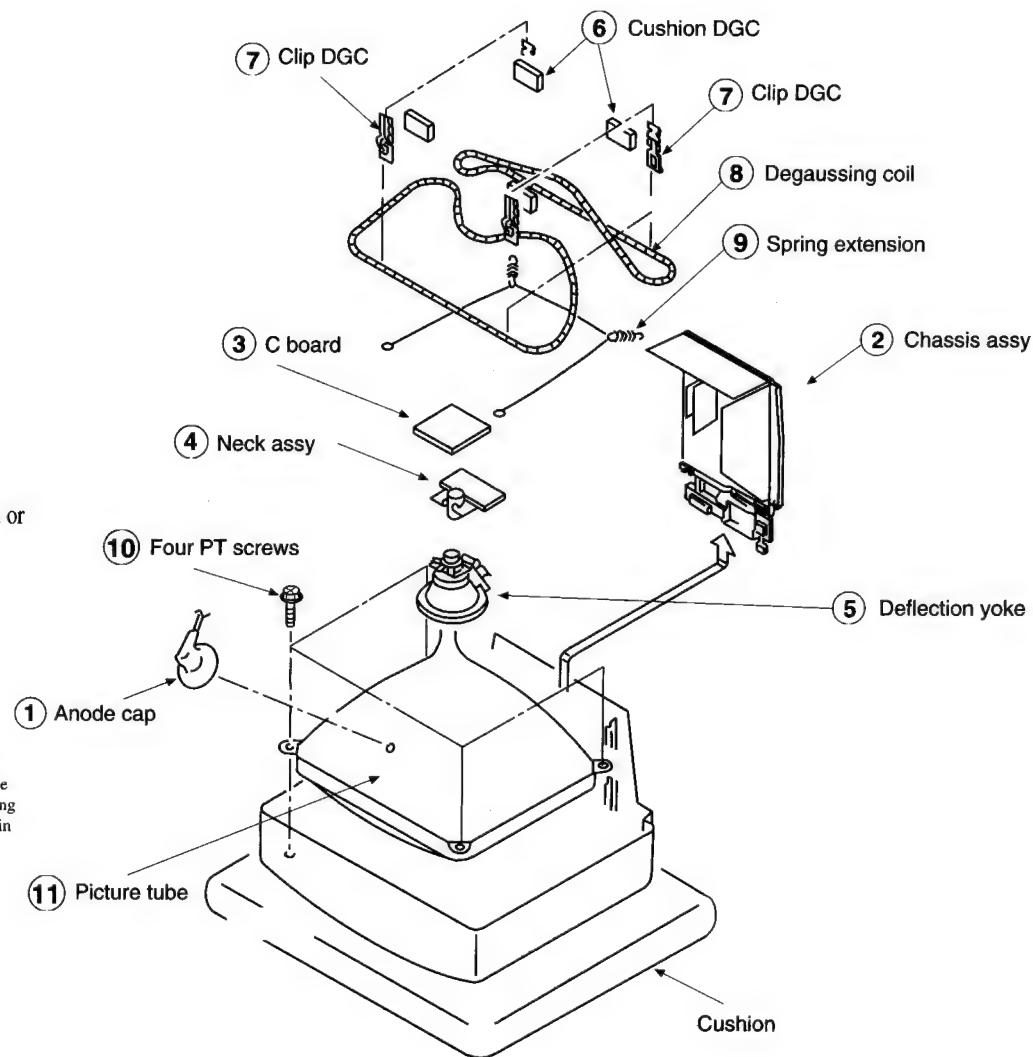

SECTION 3

SET-UP ADJUSTMENTS

- When complete readjustment is necessary or a new picture tube is installed, carry out the following adjustments.
- Unless there are specific instructions to the contrary, carry out these adjustment with the rated power supply.
- Unless there are specific instructions to the contrary, set the controls and switches as follows.

Contrast normal
 Brightness normal

- Carry out the following adjustments in this order:

- 3-1. Beam landing
- 3-2. Convergence
- 3-3. Focus
- 3-4. White balance

Note: Testing equipment required.

1. Colour bar/pattern generator
2. Degausser
3. Vector scope

3-1. BEAM LANDING

Preparation:

1. In order to reduce the influence of geomagnetism on the set's picture tube face it in an easterly or westerly direction.
2. Switch on the set's power and degauss with the degausser.

(1) Adjustment of Correction Magnet for Y-Splitting Axis

1. Input a crosshatch signal from the pattern generator.
2. Picture control is minimum and brightness control is still normal.
3. Position the neck assy as shown in Fig. 3-2.
4. Move the deflection yoke forward to touch the CRT and it stands up rightly.
5. Adjust the upper pin and the lower pin symmetrically by opening or closing the Y-splitting axis correction magnets on the neck assy.
6. Return the deflection yoke to its original position.

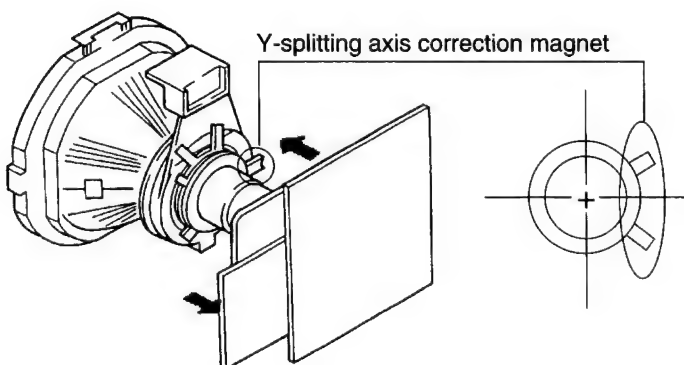

(2) Landing

Note: Before carrying out the following adjustments adjust the magnets as indicated below (See Fig.3-3).

1. Input an all-white signal from the pattern generator. Maximize the picture setting and adjust the brightness setting.
2. Rough-adjust the focus and horizontal convergence.
3. Loosen the deflection yoke screws, align the purity adjustment knob to the central position. (See Fig. 3-1)
4. Switch from the all-white pattern to an all-green pattern.
5. Move the deflection yoke backwards and adjust with the purity magnet so that the green is at the center and it aligns symmetrically. (See Fig. 3-4)
6. Move the deflection yoke forward and adjust so that entire screen becomes green.
7. Switch the raster signal to red, then to blue and verify the landing condition.
8. When the position of the deflection yoke has been determined, fasten the deflection yoke with the screw.
9. If the beam does not land correctly in all the corners, use magnets to correct it. (See Fig. 3-5)

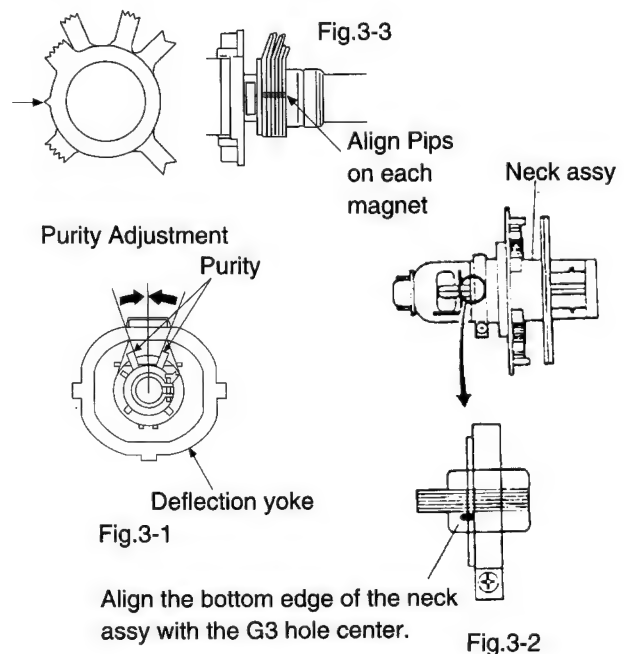

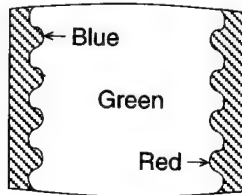

Fig.3-4

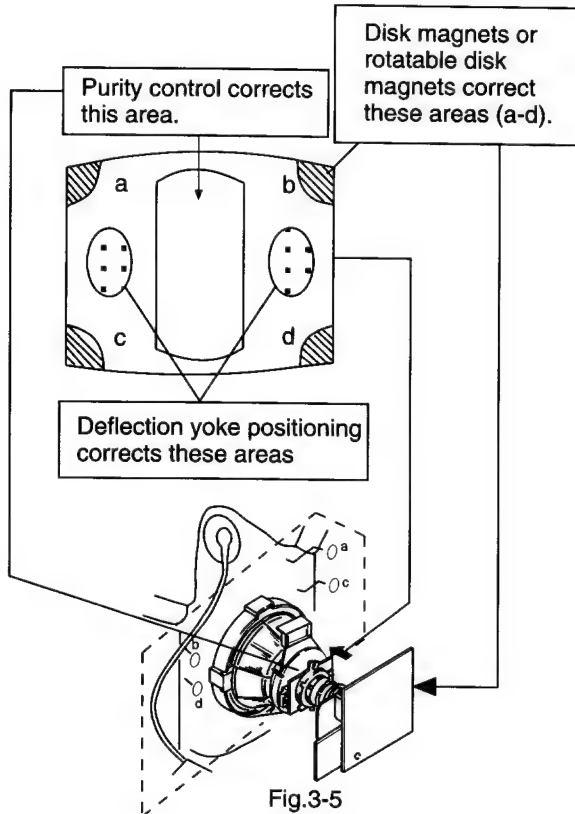
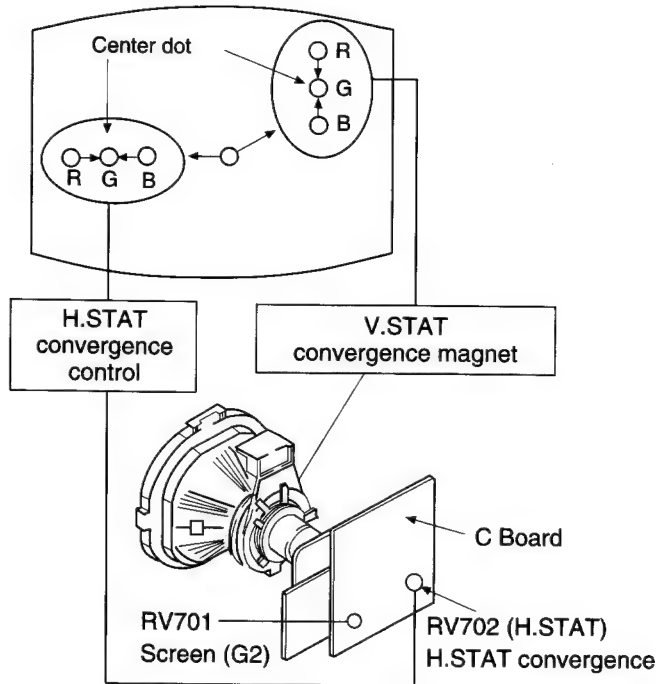
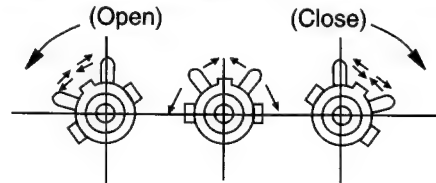

Fig.3-5



- If the horizontal dots are unable to coincide with the variable range of the H.STAT convergence, adjust together with the V.STAT convergence while tracking. (Adjust the convergence by tilting the V.STAT convergence or by opening or closing the V.STAT convergence.)



3-2. CONVERGENCE

(1) Screen center convergence (Static convergence)

1. Input a dot signal from the pattern generator. Normalize the picture setting.
2. (Moving horizontally), adjust the H.STAT control so that the horizontal red, green and blue dots coincide at the center of screen.
3. (Moving vertically), adjust the V.STAT magnet so that the vertical red, green and blue points coincide at the center of screen.

4. Movement of the red, green and blue dots by tilting the V.STAT magnet and by opening or closing the V.STAT magnet.

- ① By opening or closing the V.STAT magnet, the red, green and blue points move as shown below

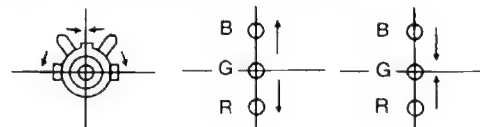

- ② By rotating the V. STAT magnet counterclockwise, the red, green and blue dots move as shown below.

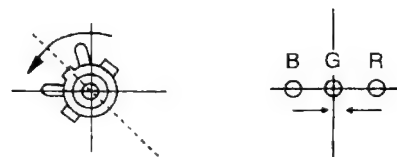

- ③ By rotating the V.STAT magnet clockwise, the red, green and blue dots move as shown below.

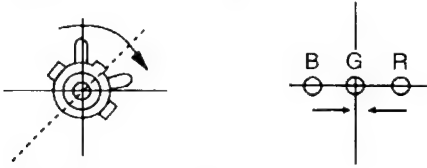

- ④ By opening or closing the V.STAT magnet, the red, green and blue dots move as shown below.

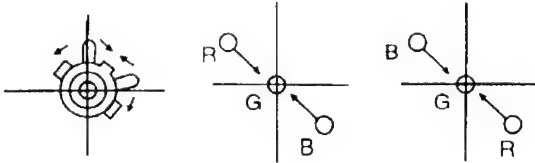

- If the blue dot does not coincide with the red and green points, correct the points by using the BMC (Hexapole) magnet.
- ⑤ Correction for HMC (horizontal mis-convergence) and VMC (vertical mis-convergence) by using the BMC (Hexapole) magnet.

- ① HMC correction by BMC (Hexapole) magnet and movement of the electronic beam.

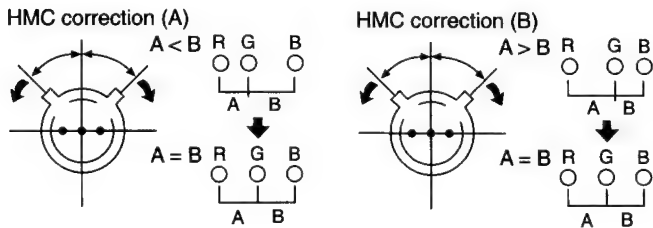

- ② VMC correction by BMC (Hexapole) magnet and movement of the electronic beam.

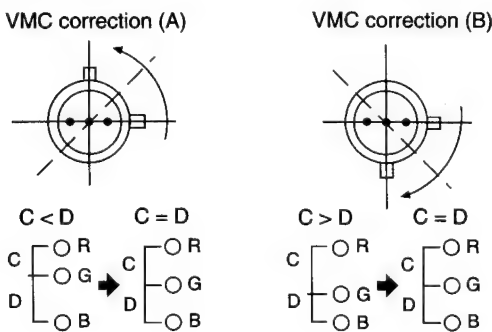

Layout of each control

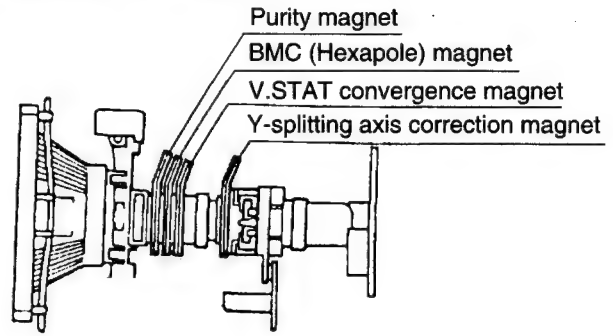
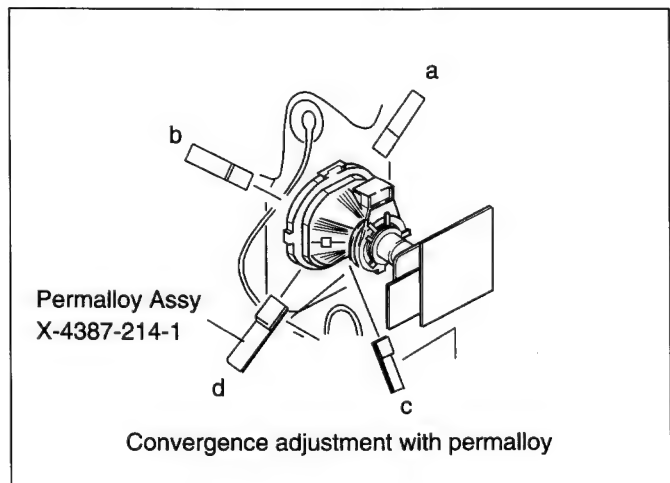
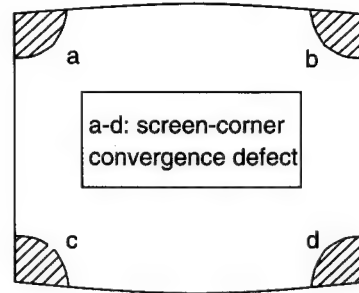

Fig.3-5

- If you are unable to adjust the corner convergence properly, correct them with the use of permalloys.



3-3. Focus

1. Receive a television broadcast signal.
2. Normalize the picture setting.
3. Adjust the focus control on the flyback transformer for the best focus at the center of the screen.
Bring only the center area of the screen into focus, the magenta-ring appears on the screen. In this case, adjust the focus to optimize the screen uniformly.

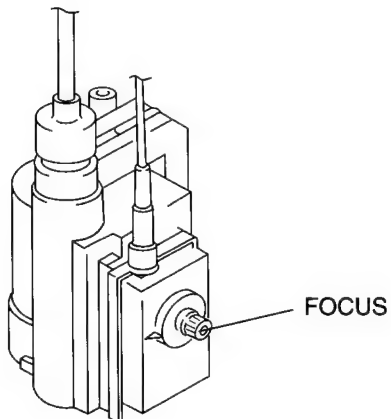

3-4. Screen (G2), White balance (Adjustment in the service mode with remote commander)

G2 adjustment (RV702)

1. Input a dot signal from the pattern generator.
2. Set the Picture, Brightness and Colour to minimum.
3. Apply 170V DC from an external power supply to the R, G and B cathodes of the CRT.
4. Whilst watching the picture, adjust the G2 control RV701 [SCREEN] on the C board to the point just before the return lines disappear.

White balance adjustment

1. Receive an all-white signal.
2. Enter into the Service Mode by pressing 'TEST', 'TEST' and '01' on the Service Commander.
3. Select 'CRT Driver' from the on screen menu display and press **OK**.
4. The 'CRT Driver CXA1840' menu will appear on screen.

CRT Driver CXA 1840

Crt Driver		CXA1840
21	R DRIVE	41
22	G DRIVE	adj
23	B DRIVE	adj
24	R CUT-OFF	10
25	R C	0
26	G CUT-OFF	adj
27	G C	0
28	B CUT-OFF	adj
29	B C	0
30	AFC MASK	0
31	DRIVE LVL	52
32	SUB BRT	adj
33	H SWEEP SW	on
34	SKEW D	off
35	OUT DC	0

5. Set picture to MAX.
6. Set the 'R DRIVE' to 41.
7. Adjust the 'G DRIVE' and 'B DRIVE' with the **▲** **▼** buttons so that the white balance becomes optimum.
8. Press the **OK** button to write the data for each item.
9. Set picture to MIN.
10. Adjust 'R CUT-OFF', 'G CUT-OFF' and 'B CUT-OFF' with the **▲** **▼** buttons so that the white balance becomes optimum.
11. Press the **OK** button to write the data for each item.

SECTION 4 CIRCUIT ADJUSTMENTS

4-1. ELECTRICAL ADJUSTMENTS

Service adjustment to this model can be performed with the supplied remote commander, RM-831.

HOW TO ENTER INTO SERVICE MODE

1. Turn on the main power switch of the set while pressing the + (plus) and - (minus) buttons on the customer front panel.

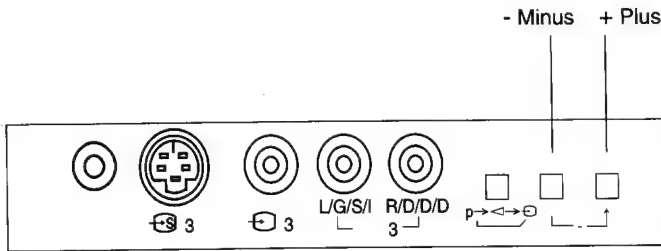

Fig. 4-1

2. "TT" will appear on the upper right corner of the screen.

Command operation in service mode

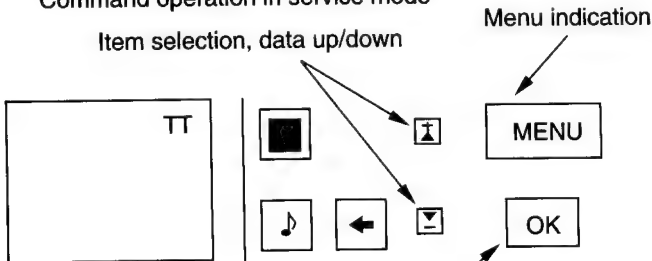

Fig. 4-2

Fig. 4-3 Selection completion, data written-in

3. Press "Test" "Test" and 01 on the commander to get the menu on screen.

AE - V7-62	AE-3	08/06/95
Init TV		
PIP Adjust		
Adjustments		
Video Contr		
CRT Driver		
Dynamic Conv		
Video Proc		
PIP		
PIP Dynamic		
Aspect / Field		
SRC		
TDA6812		
PALPLUS		
TDA9160		
TDA9145		

4. Press the and buttons on the remote commander to select the adjustment item.
5. Press the button to proceed to the next menu.
6. If the adjustment item is 'CRT Driver', press the button to move to 'CRT Driver'.
7. The Menu as indicated in Fig 4-4 will appear on the screen.

	CRT Driver	CXA1840
1	V POS	adj
2	V SIZE	adj
3	V LIN BAL	adj
4	V LIN	adj
5	V SCROLL	127
6	V ASP PAP	2
7	H POS	adj
8	H SIZE	adj
9	H PIN CUSH	adj
10	H TILT	adj
11	H UP COR	adj
12	H LOW COR	adj
13	AFC V BOW	adj
14	AFC V ANGLE	adj
15	V COMP	5



Fig. 4-4

8. Press the button to move > to the adjustment item and press the button.
9. Press the and buttons to change the data in order to comply with each standard.
10. Press the button to write data into memory.
11. Turn off the power to quit the service mode when adjustments have been completed.

CXA1839 (VIDEO CONT)

Item No	Adjustment item	Data Amount
1	SUB BRT	8
2	SUB COL1	8
3	SUB CONT1	8
4	PIC	53
5	HUE	31
6	COL	31
7	BRT	31
8	SHP	31
9	SUB HUE	7
10	D.COIL	off
11	SHP LIM	off
12	AGE WHT	off
13	R-Y/R	13
14	R-Y/B	15
15	G-Y/R	7
16	G-Y/B	5
17	RGB LEV2	8
18	SUB SHP	1
19	SUB FO	2
20	PRE/OVER	0
21	NR LEVEL	1
22	DC TRAN	0
23	DYN PIC	1
24	CEC LEVEL	2
25	VM LEVEL	2
26	ABL MODE	1
27	DYN ABL	off
28	Y SYM SW	off
29	AGE BLK	off

CXD2035 (ASPECT)

Item No	Adjustment item	Data Amount
1	COMPRESS	7
2	FRAME WID	5

CXD2030 (VIDEO PROCESSOR)

Item No	Adjustment item	Data Amount
1	DNR	on
2	DNR VALUE	5
3	TA SYN CLP	16
4	TB BGP	50
5	TD CLP	25
6	FOTO CD SW	off
7	BLK PORCH	16
8	NT TD BGP	25
9	PAL TD BGP	25
10	N.SECAM TB	50
11	SECAM TB	50
12	358 NR LVL	3
13	443 NR LVL	5

CXD2033D (PIP DYNAMIC)

Item No	Adjustment item	Data Amount
1	443DSP BGP	19
2	358DSP BGP	38
3	SE DSP BGP	19
4	443 LRD H	39
5	358 LRD H	41
6	443MN MPWH	213
7	358MN MPWH	174
8	443 ACC R.	52
9	358 ACC R.	42
10	443MN R RD	39
11	358MN R RD	27
12	FRAME PIP	10
13	FRAME MPX	3

Typical Value (OSD based) when receiving PAL Philips pattern.

DEFLECTION SYSTEM ADJUSTMENT

1. Enter into the service mode and select 'CRT Driver'.The 'CRT Driver CXA1840' adjustment menu will be displayed.
2. Select and adjust each item in order to get an optimum image.

Item No	Adjustment item	Data Amount
1	V POS	adj
2	V SIZE	adj
3	V LIN BAL	adj
4	V LIN	adj
5	V SCROLL	127
6	V ASP PAP	2
7	H POS	adj
8	H SIZE	adj
9	H PIN CUSH	adj
10	H TILT	adj
11	H UP COR	adj
12	H LOW COR	adj
13	AFC V BOW	adj
14	AFC V ANGLE	adj
15	V COMP	5
16	H COMP	0
17	WV CENT RF	144
18	WV AREA RF	36
19	W CENT VCR	160
20	W AREA VCR	20

H SIZE

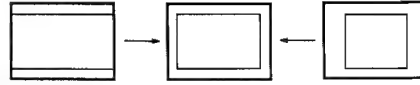

H PIN CUSH

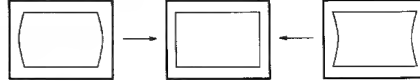

H TILT



H UP COR



H LOWER COR



AFC V BOW

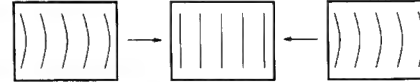

AFC V ANGLE



H POS



3. Press **OK** button to write the data.

If the menu display prevents viewing the screen while carrying out the adjustments, it can be removed by pressing **⏏** on the remote commander. Pressing **⏏** once again will restore the menu on screen.

V SIZE



V POS

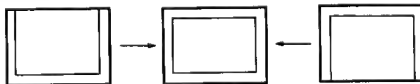

V LIN



4-2. VOLUME ELECTRICAL ADJUSTMENTS

AGC Adjustment (IF Block)



- IF Block top side -

Fig. 4-5

1. Receive an off-air signal.
2. Adjust the AGC VR so that there is no snow noise and cross-modulation visible on the screen.
3. Change the receiving channel and confirm status.

Sub Brightness Adjustment

1. Input a Phillips pattern.
2. Select 'RESET' from the menu to normalize the set.
3. Set the CONTRAST to minimum.
4. Press "Test" "Test" and 01 on the remote commander.
5. Adjust the BRIGHTNESS with the +/- buttons on the remote commander after selection of 'Sub Bright' so that the 0 IRE section of the gray scale is completely cut off and the 20 IRE section is only just visible on the screen.
6. Press 'MENU' and '0' twice to release Test mode 2.
7. Select 'RESET' from the menu to normalize the set.

Picture Rotation Adjustment

1. Input a PAL color bar signal.
2. Press the **MENU** button on the commander to get the menu on screen.
3. Press the **▲** and **▼** buttons of the commander and move > to PRESET/TIMER followed by INSTALLATION and PICTURE ROTATION.

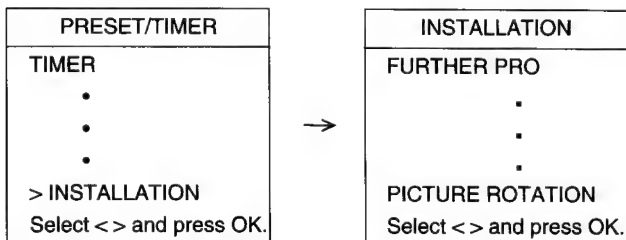

Fig. 4-6

4-3. TEST MODE 2:

Is available by pressing the Test button twice, OSD "TT" appears. The functions described below are available by pressing the two numbers. To release Test Mode 2, press 0, 10, 20 ... twice or switch the TV into Standby Mode. Pressing the two Local Control buttons (+ and -) during Power ON will also switch into "TT" mode.

In TT mode, it is possible to remove the Menu from the screen by pressing the Speaker Off button once. Pressing the Speaker OFF button a second time will cause the menu to reappear . The Function is kept even when the menu is not displayed!!

00	Switch back to normal mode - TT mode off	16	Save actual Last Power Memory data at Reset Data location)The previous Reset data is overwritten)
01	Switch service menu on	15/16	With these two functions, it is possible to preset user defined Reset values (just TT16) or to preset factory defined Reset values (first TT15 then TT16)
02	Direct access to Noise reduction	17	This function presets the Labels for the AV sources: AV1, RGB, AV2, YC2, AV3, YC3, AV4, YC4.
03	Set Volume to 30%	18	Text possible On/Off selection of Text (toggle function)
04	Service Menu in "Service Mode"	19	Direct access to Stereo Separation With cursor Up/Down the Stereo separation can be adjusted (w/o OSD, Menu display)
05	Service Menu in "Production Mode"	20	see TT10
06	Set Volume to 80%	21	Picture Rotation automatic function : (-4) -> (+4) -> 0
07	Aging mode	22	Operating Timer and Error Monitor display
08	Shipping condition (Production request) To ensure that all TV sets leave the Production with the same presettings. Programme 1 is selected, AV IN is set to AV1, AV Out is set to TV Out, Volume and HP Volume is set to 35%, Resolution is set to high, Format is set to 4:3, Pip is set to Top Left position, Pip is switched off, TT mode is switched off, all analogue values are set to the reset setting, space Sound - Equalizer - Loudness = off, DNR off, Dig. Mode = 1, Wide Zoom Mode for 28W models, Menu Language Reset, Prog. Pointer table reset Non Interlace is allowed in Text mode.	23	Direct access to Sub Brightness Adjustment With cursor Up/Down the Sub BRT can be adjusted (w/o OSD, Menu display)
09	Language reset. With this function the "Language Byte" in the NVM (Bank 0AAH Address 0DCH) is erased (set to 0FFH). The Language Menu appears now automatically when the TV set is switched ON as long as no new language is selected.	24	Direct access to Sub Color. With Cursor Up/Down the Sub Color can be adjusted.
10	The TT number will be deleted. All numbers with 0 (10, 20, 30, 40, 50, 60, 70, 80, 90) will reset the TT number. A new number can be selected. TT display is kept	25	Status menu display (SubController, CXA1840 Status, Main Controller.
11	Direct access to Balance. With Cursor Up/Down the Balance can be controlled (w/o OSD, Menu display)	26	Text Character selection (Char set 06 ->West Europe)
12	Direct access to Hue. With Cursor Up/Down the Hue can be controlled (w/o OSD, Menu display)	27	Text Character selection (Char set 38 ->East Europe)
13	Dispaly of Software Version and TV set configuration	28	Text Character selection (Char set 40 ->West Europe) US English
14	Production Info Display	29	Text Character selection (Char set 55 ->West Europe) Turkish
15	Read factory setting from ROM (Program code) and store this data at Last Power Memory data location (The previous last power memory data is overwritten) AE3 has 3 packages of Analogue data: 1. Last Power memory data. This data is sent continously to the corresponding IC's (TDA1839, SC, TDA6812) with this data the TV picture/sound appears. 2. Reset data. By presssing "Reset" in the menu this data is transferred from Reset Data location to the Last Power data location in the NVM. That means the Last Power Memory Data is overwritten by the Reset data last Power memory and Reset data is now the same. 3. Factory fixed data. Fixed data is held in the ROM code of the micro processor (ROM can't be changed)	30	see TT10
		31	Text Character selection Char set Russian
		32	Text Character selection Char set Greek
		33	Programme catching test (Programme catching can be released by "Menu command")
		34	Multi PIP adjustment. Direct access to 3.58 horizontal write position. With Cursor Up/Down the 3.58 H write Pos can be adjusted (w/o OSD, Menu display).
		35	Multi PIP adjustment. Direct access to 4.43 horizontal write position. With Cursor Up/Down the 4.43 H write Pos can be adjusted (w/o OSD, Menu display).
		36	Mtx Register 112 = intern display clock
		37	Mtx Register 112 = extern display clock

38	Automatic selection of Screen Modes: (not for S (4:3) Models. 4:3 -> Zoom -> Zoom up -> Zoom Center -> Zoom down -> Zoom Center -> smart -> (if Pal+ signal) PALPLUS -> wide.
39	Reset Programme Table (NVM Bank 0ACH) The sorting of programmes in "Programme Sorting Menu" is reset.
40	see TT10
41	no function
42	no function
43	no function
44	no function
45	Set NVM to Protect mode (Bank 0AEH Adr. 0FFH write with 0)
46	IR Channel Pressetting Mode. The channel pressetting can be done by a Special IR transmitter Sequence: TT46 -> -- PR Number select display appears Select Prog. No from where the channel shall be stored. --> Now TV is waiting for IR sequence <-- --> If no IR transmission starts TT46 is released after 20 secs <-- !Note: When TT46 is active, any transmission will be interpreted as PROG data !
47	Direct access to Headphone Source Selection (Production use)
48	Direct access to AGC Adjustment (PWM) output.
49	The EEPROM Testbyte is erased. After Power OFF -> ON the complete EEPROM data (except channel tables) is overwritten. EEPROM Protection byte is set to 0 protection mode
50	see TT10
51	Strobo mode is activated.
52	no function.
53	Photo mode test (Photo mode can be released by "Menu command").
54	Direct access to Velocity Modulation VM (Production use)
55	MTX Slicer Control "Low Pass" (only Sys L)
56	MTX Slicer Control "No Compensation"
57	Megatext Service Menu ON
58	MTX Small Framing Code Window
59	MTX Wide Framing Code Window
60	see TT10

61	Set Dolby default values.
62	ACI disable.
63	ACI enable.
64	Reset all IIC Slave commands (Production use)
65	Reset stored error codes in NVM.
66	Reset for PALplus local controller and Sub Controller.
67	Direct access to Headphone Volume. With cursor Up/Down the Headphone Volume can be controlled (w/o OSD, menu display) (Production use)
68	ignore errors.
69	reset ignore errors (show errors)
70	see TT10
71	Picture Rotation Function On/Off toggle.
72	Dolby register setting menu.
73	Megatext RGB textlevel one step decreased (max 3 steps down starting from E0h) (Production use)
74	Megatext RGB textlevel one step decreased (max 1 steps down starting from E0h) (Production use)
75	reserved
76	CXD 2030 Default data setting.
77	CXD 2031 Default data setting
78	CXD 2032 Default data setting
79	CXD 2033 Default data setting
80	see TT10
81	CXD 2033D Default data setting
82	CXD 2035 Default data setting
83	CXA 1526 Default data setting
84	CXA 1839 Default data setting
85	CXA 1840 Default data setting
86	TDA 9145 Default data setting
87	TDA 9160 Default data setting
88	no function
89	no function
90	see TT10

4-4. ERROR MONITOR AND DETECTION

In the menu 'Error Monitor', information about the error status of the set is displayed.

- Actual operating time
- Last five errors which are stored in the NVM.
- Actual error.

Error Monitor	
Operating Time	000355 h 35min
Saved Errors	1. 40h=D1 Board 2.. 60h=Q Board 3. 70h=T Board 4. 00h=no error occurred 5. 00h=no error occurred
Actual Error	-> 00h=no error occurred
to reset the NVM press 'TT' 65	

Additionally the Error Reader can be connected to the service connector to read out the actual errors.

The device check itself is active while the TV set is running out of stand-by mode. The devices are checked by sending an I²C start sequence and if there is no acknowledgement back from the devices it is regarded as an error. Each device is checked three times and if at every attempt there is no reply from the relevant device an error is given. To read the error codes press 'TT' followed by 22 on the commander to view the Error Monitor menu.

To reset the error codes in the NVM press 'TT' followed by 65 on the remote commander.

TABLE OF ERROR CODES

Error Code	Device	Description	Board
000h	no device	no error has occurred	-
001h	IIC 1 and IIC 2	IIC 1 and IIC 2 blockaded	-
002h	IIC 1	IIC1 is blockaded	-
003h	IIC 2	IIC 2 is blockaded	-
010h	A Board	A Board is defective	-
020h	A1 Board	A1 Board is defective	-
030h	BX-Board (B,B1,B2)	B, B1, or B2 Board is defective	-
040h	D1 Board	D1 Board defect	-
050h	J Board	J Board defect	-

Error Code	Device	Description	Board
060h	Q Board	Q Board defect	-
070h	T Board	T Board defect	-
011h	CXP85332	No response from the Subcontroller	A
012h	ST24C16	No response from the NVM	A
013h	SDA5273	No response from the Megatext IC	A
014h	TDA6812	No response from the Sound Processor	A
015h	SAA7283	No response from the Nicam Decoder	A
016h	UV916H	No response from the Main Tuner	A
017h	CXA1839Q	No response from the Video Controller	A
018h	CXA1840	No response from the CRT Driver	A
019h	RGB8443	No response from RGB/YUV	A
021h	TDA6622	Audio processor of the Center and Surround channel in the case of Dolby Prologic does not respond.	A1
022h	TDA7317	No response from the Equalizer.	A1
031h	CXD2030R	No response from the Digital Video Processor.	B/B1
032h	CXD2031R	No response from the Twin Picture IC.	B1
033h	CXD2032R	No response from the Digital Sampling Rate Converter.	B/B1
034h	CXD2033R	No response from the Picture in Picture IC.	B
035h	CXD2035R	No response from the Aspect Converter.	B/B1
036h	TDA9160	No response from the Chroma Decoder.	B/B1
037h	TDA9145	No response from the Chroma Decoder (on French models only.)	B2
041h	CXA1526	No response from the Convergence IC.	D1
051h	CXA1855	No response from the AV-Switch	J
061h	83C65202	No response from the Local Controller.	Q
071h	UV1316/TSA5526	No response from the Subtuner.	T
072h	CXA1875	No response from the Port Expander.	T

4-5. LED Error Blinking

In addition to the Error Monitor facility there is an additional error indicator which indicates the most important errors also in the case of IIC error and Megatext error in opposition to the error monitor.

The error is recorded by counting the number of times that LED B blinks. This facility also works while in stand-by mode.

LED Error Code.

Error	number of LED B blinking	Description	Board
0	1	general IIC error	-
1	2	ST24C16 NVM error	A
2	3	CXP85332 subcontroller error	A
3	4	CXD2030R error of Digital Video Processor	B/B1
4	5	CXD2032R error of Digital Sampling Rate Converter	B/B1
5	6	CXD2035R error of Aspect Converter	B/B1
6	7	TDA1839 error of Video Controller	A
7	8	TDA1840 error of CRT Driver	A
8	9	CXA1855 error of AV switch	J
9	11	SDA5273 error of Megatext	A
10	12	TDA6812 error of Sound Processor	A
11	16	V-Protection (In this case the TV set is switched of immediately)	-

BLOCK DIAGRAM (1)

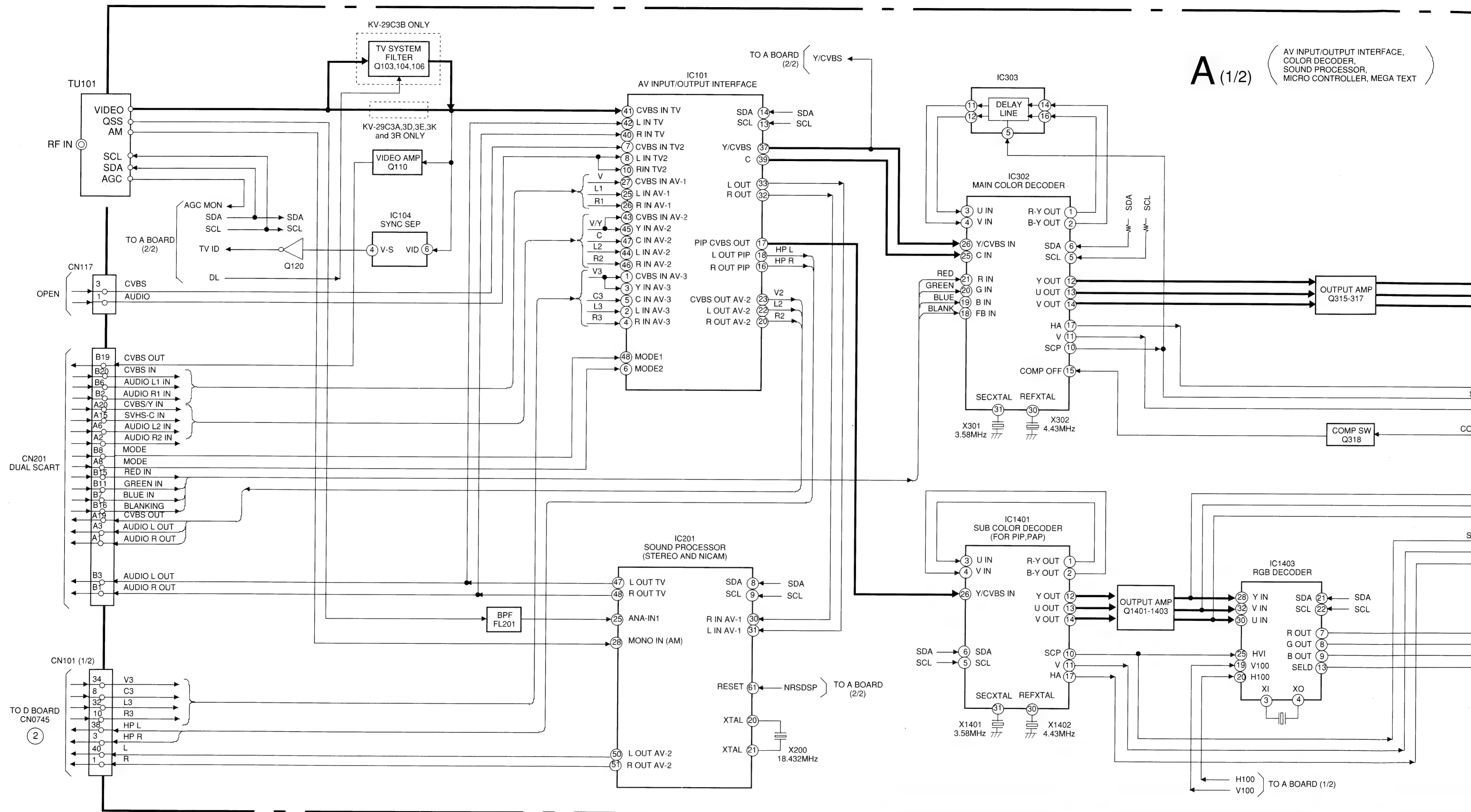

A (1/2) (AV INPUT/OUTPUT INTERFACE, COLOR DECODER, SOUND PROCESSOR, MICRO CONTROLLER, MEGA TEXT)

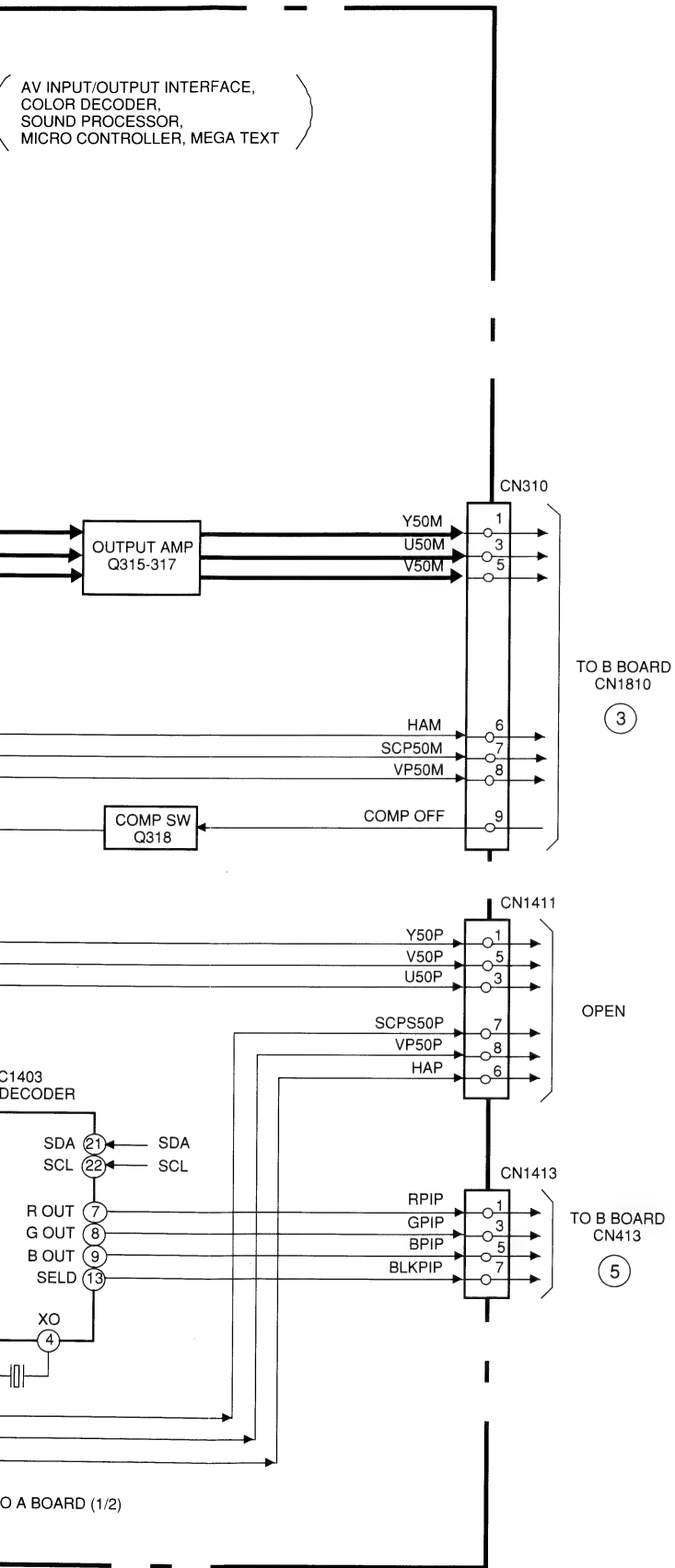

BLOCK DIAGRAM (2)

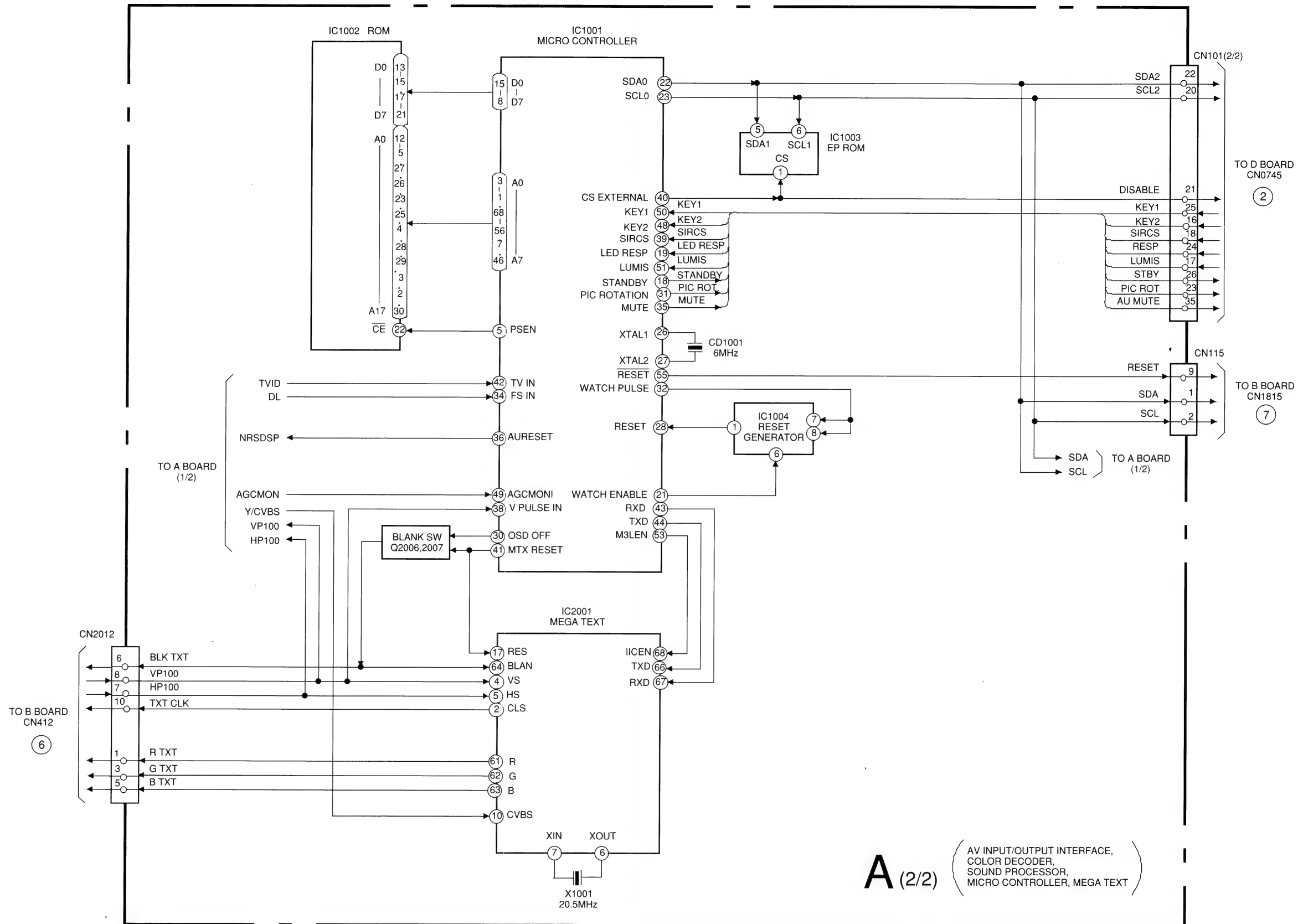

BLOCK DIAGRAM (3)

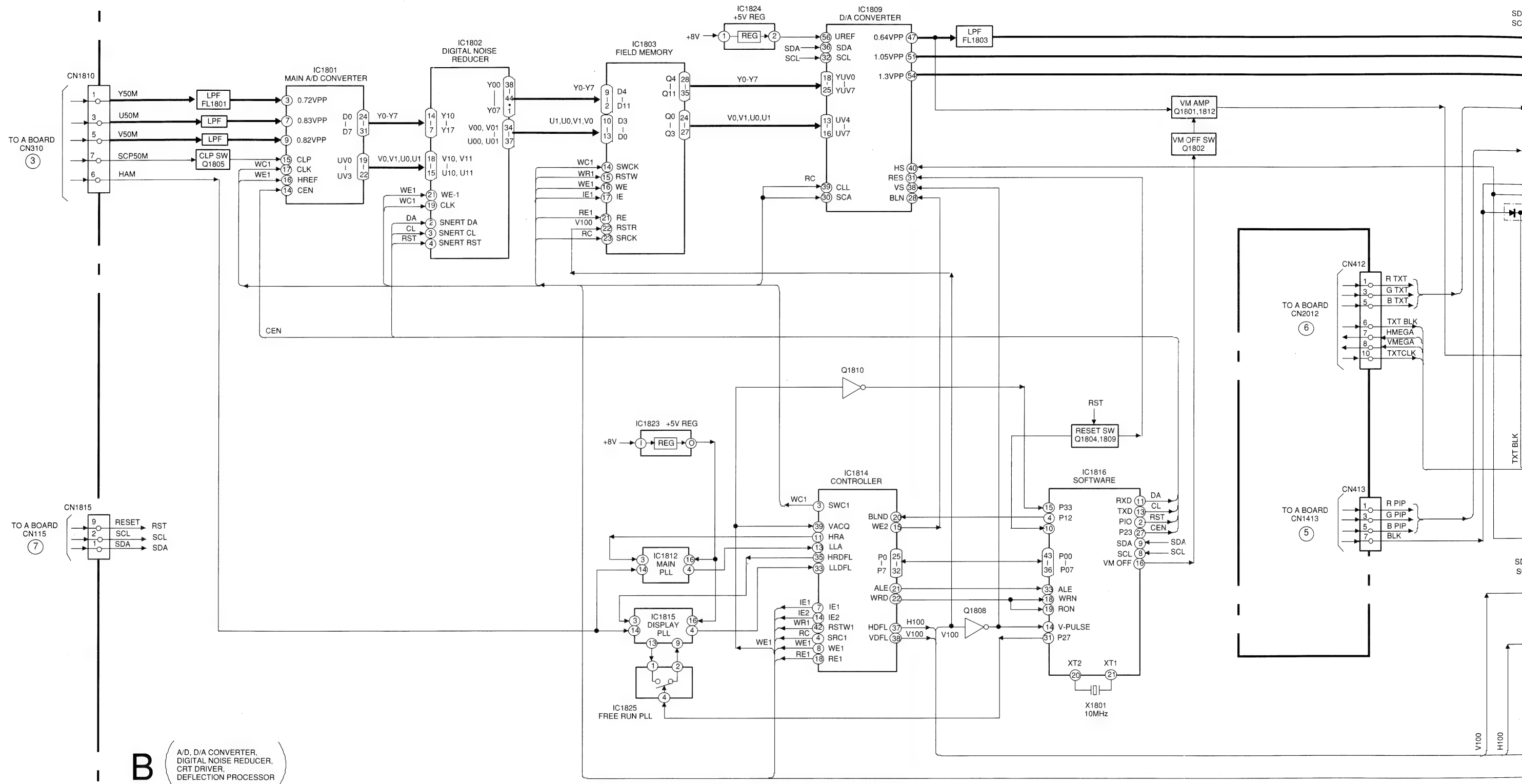

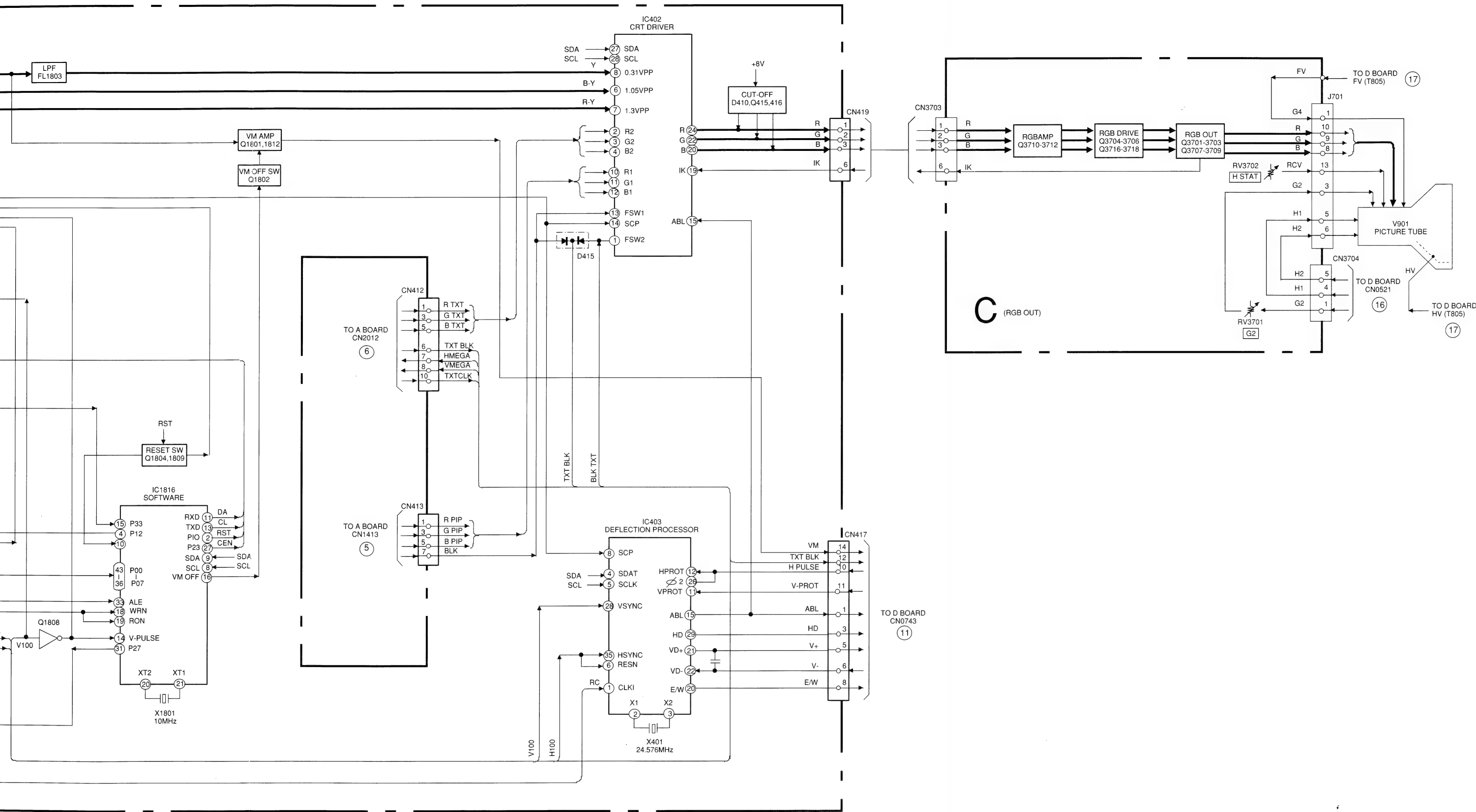

BLOCK DIAGRAM (4)

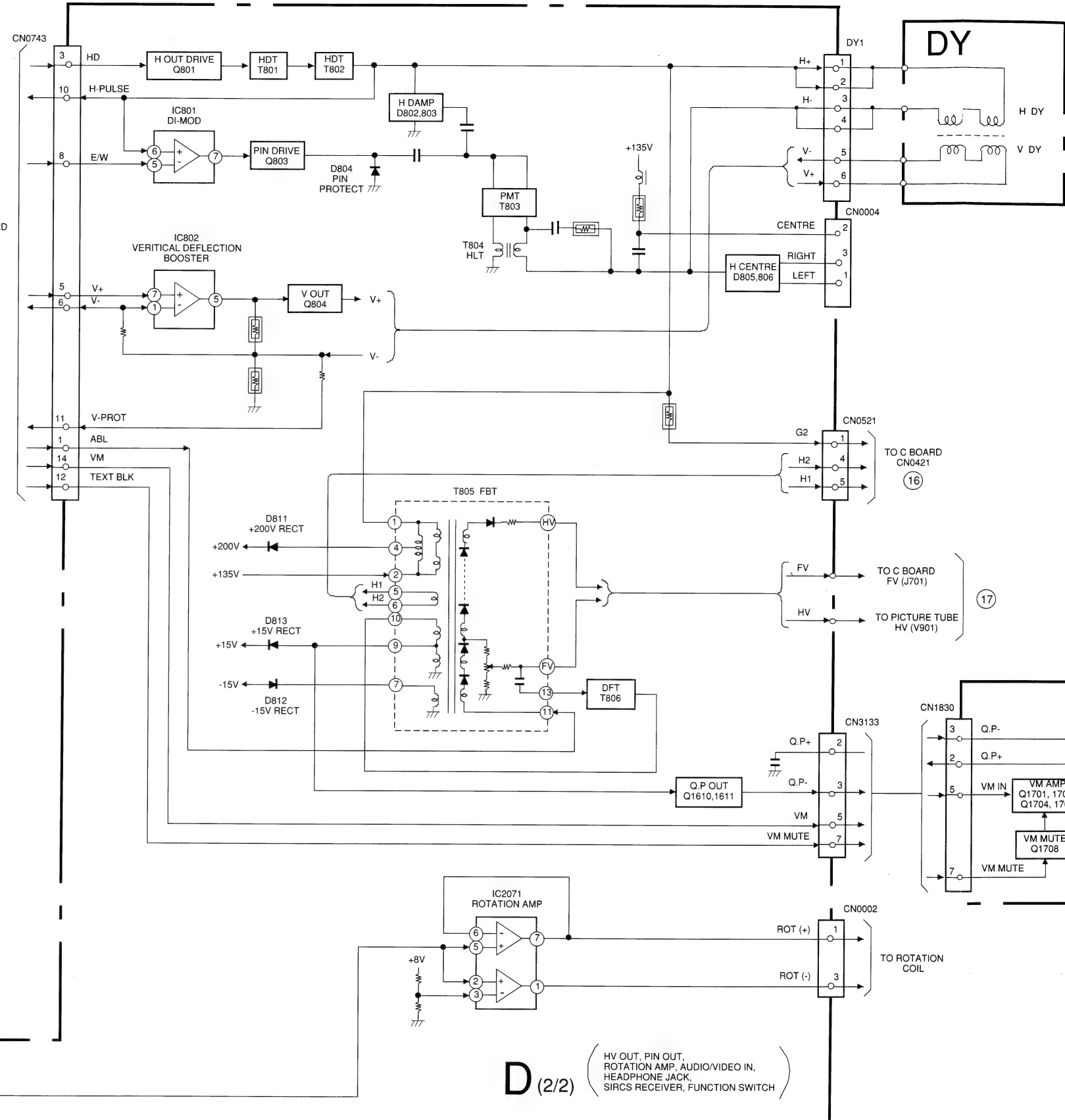
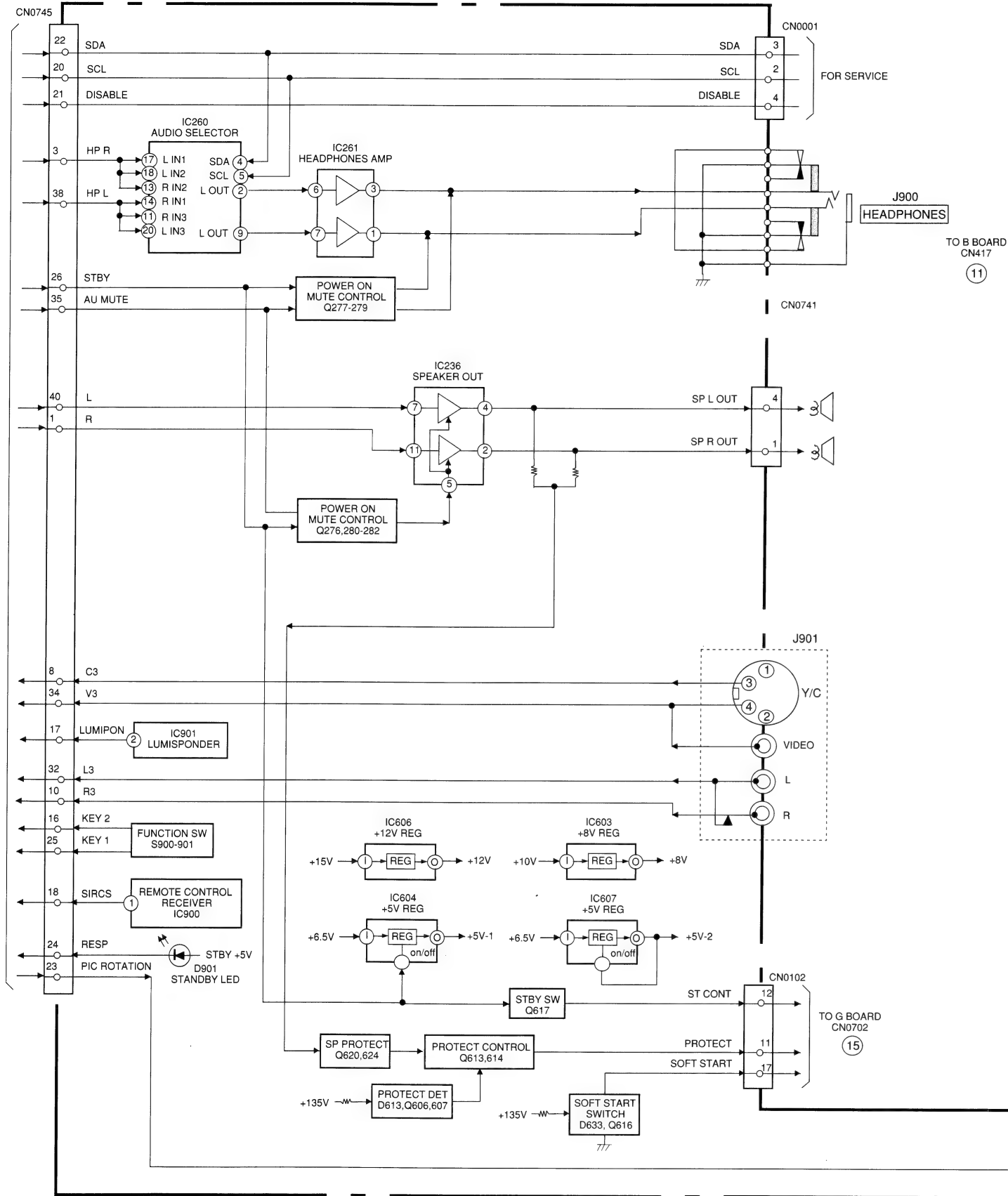

D (2/2) (HV OUT, PIN OUT, ROTATION AMP, AUDIO/VIDEO IN, HEADPHONE JACK, SIRCS RECEIVER, FUNCTION SWITCH)

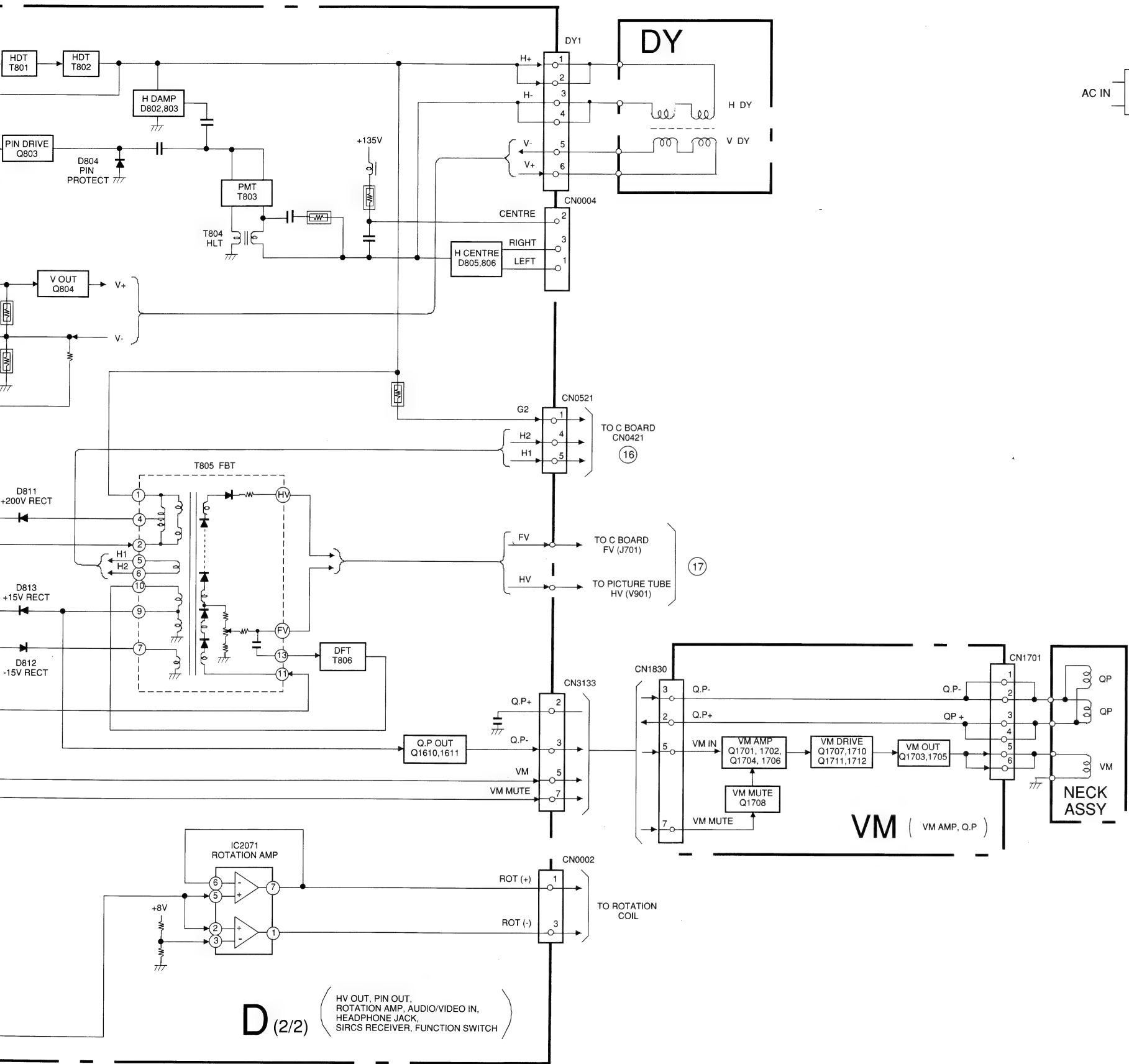

BLOCK DIAGRAM (5)

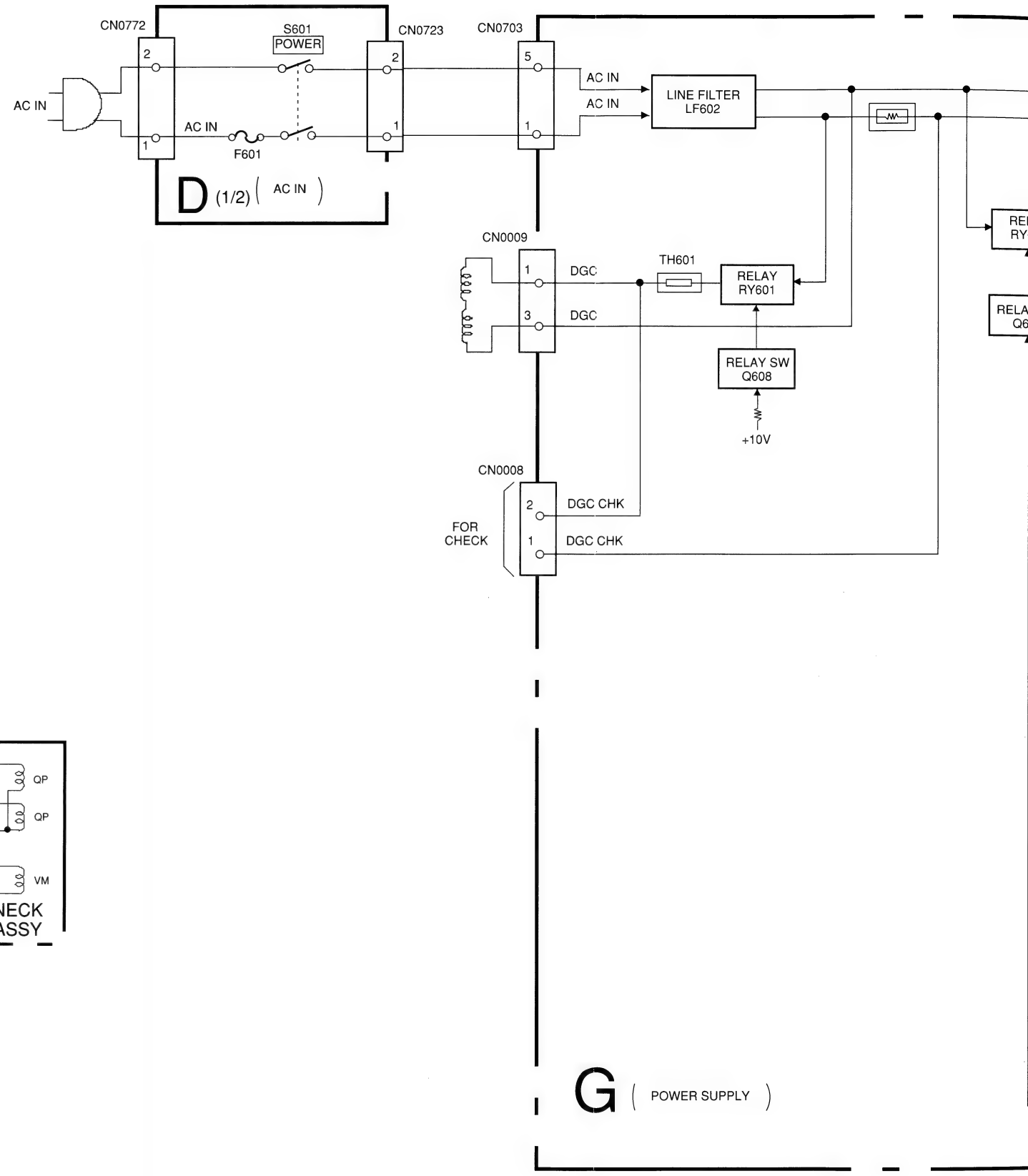

BLOCK DIAGRAM (5)

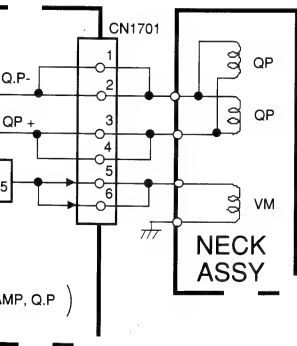
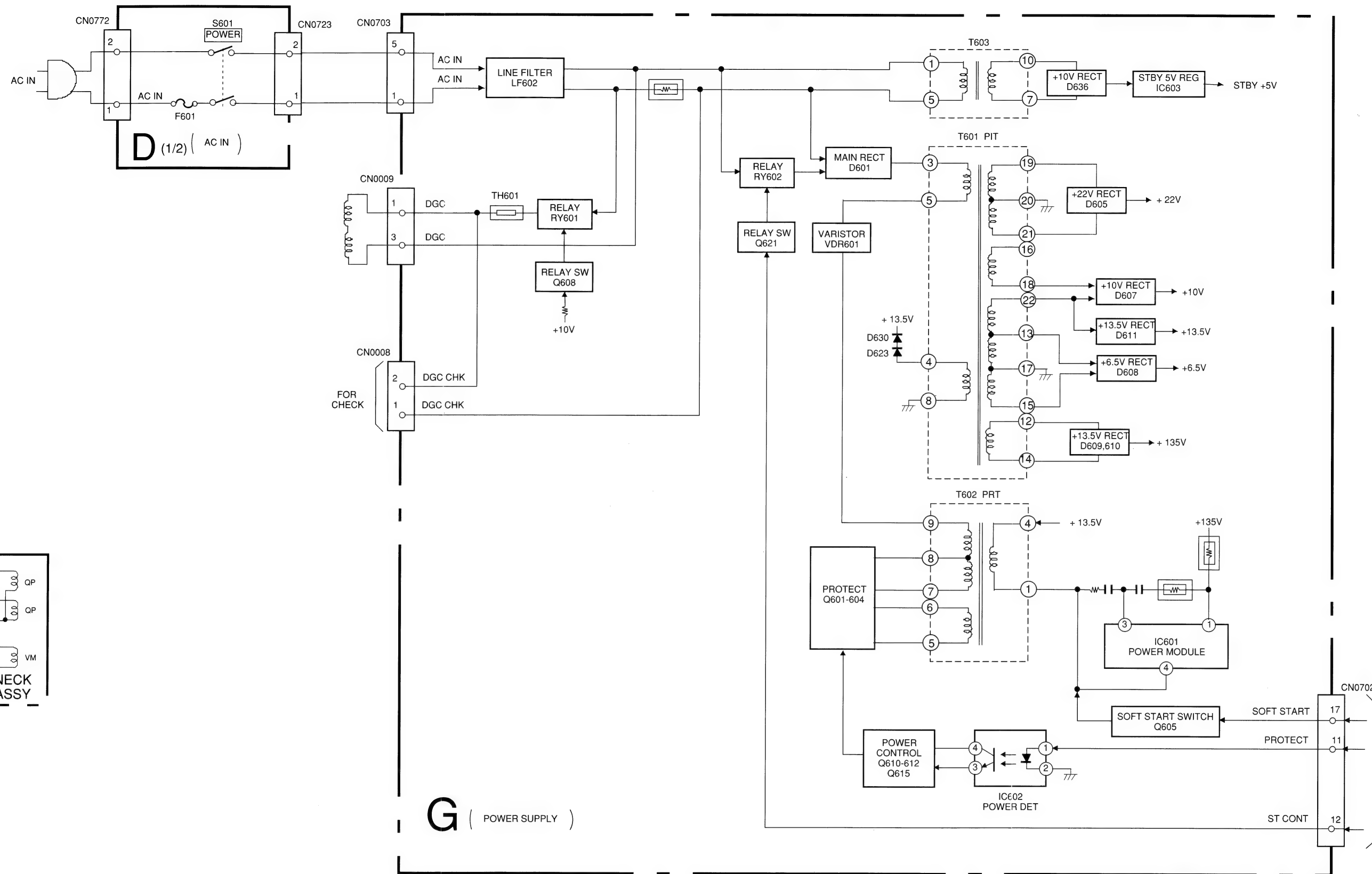

5-2. CIRCUIT BOARDS LOCATION

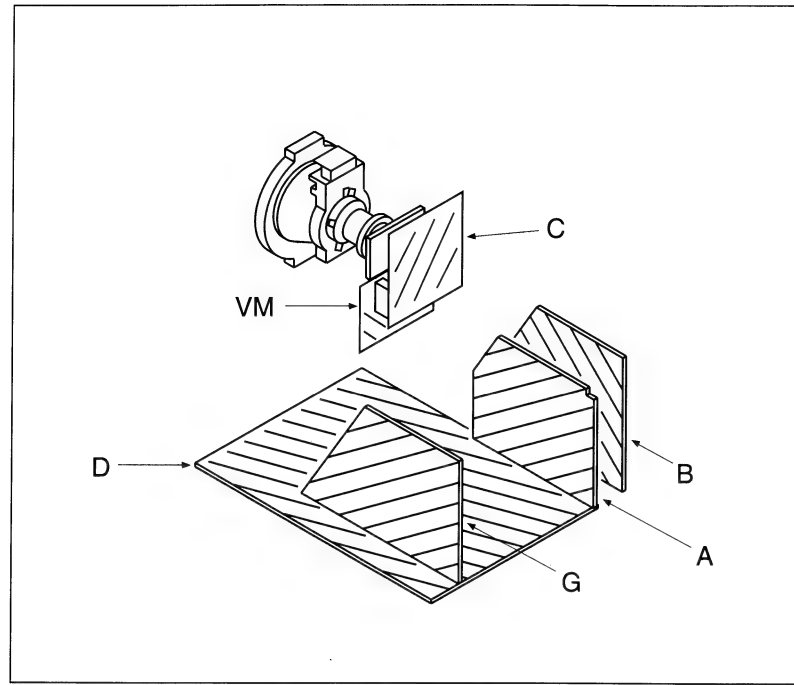

5-3. SCHEMATIC DIAGRAMS AND PRINTED WIRING BOARDS

Note :

- All capacitors are in µF unless otherwise noted. pF: µµF
• All resistors are in ohms.
• Indication of resistance, which does not have one for rating electrical power, is as follows.

Pitch : 5 mm
Rating electrical power 1/4 W

- [Symbol] : nonflammable resistor.
• [Symbol] : internal component.
• [Symbol] : panel designation, or adjustment for repair.
• All variable and adjustable resistors have characteristic curve B, unless otherwise noted.
• [Symbol] : earth - ground.
• [Symbol] : earth - chassis.
• [Symbol] : no mounted.

Reference information

Table mapping resistor codes (RN, RC, FPRD, etc.) to material types (METAL FILM, SOLID, NONFLAMMABLE CARBON, etc.)

- Readings are taken with a colour-bar signal input.
• Readings are taken with 10MΩ digital multimeter.
• Voltages are dc with respect to ground unless otherwise noted.
• Voltage variations may be noted due to normal production tolerances.
• All voltages are in V.
• Circled numbers are waveform references.
• [Symbol] : B+ bus.
• [Symbol] : signal path. (RF)

Note : The components identified by shading and marked with a triangle are critical for safety. Replace only with the part number specified.

Note : Les composants identifiés par une trame et une marque sont critiques pour la sécurité. Ne les remplacer que par une pièce portant le numéro spécifié.

A BOARD

Component list table for A BOARD with columns for IC, Transistor, Diode, and other parts.

A Board < Conductor Side >

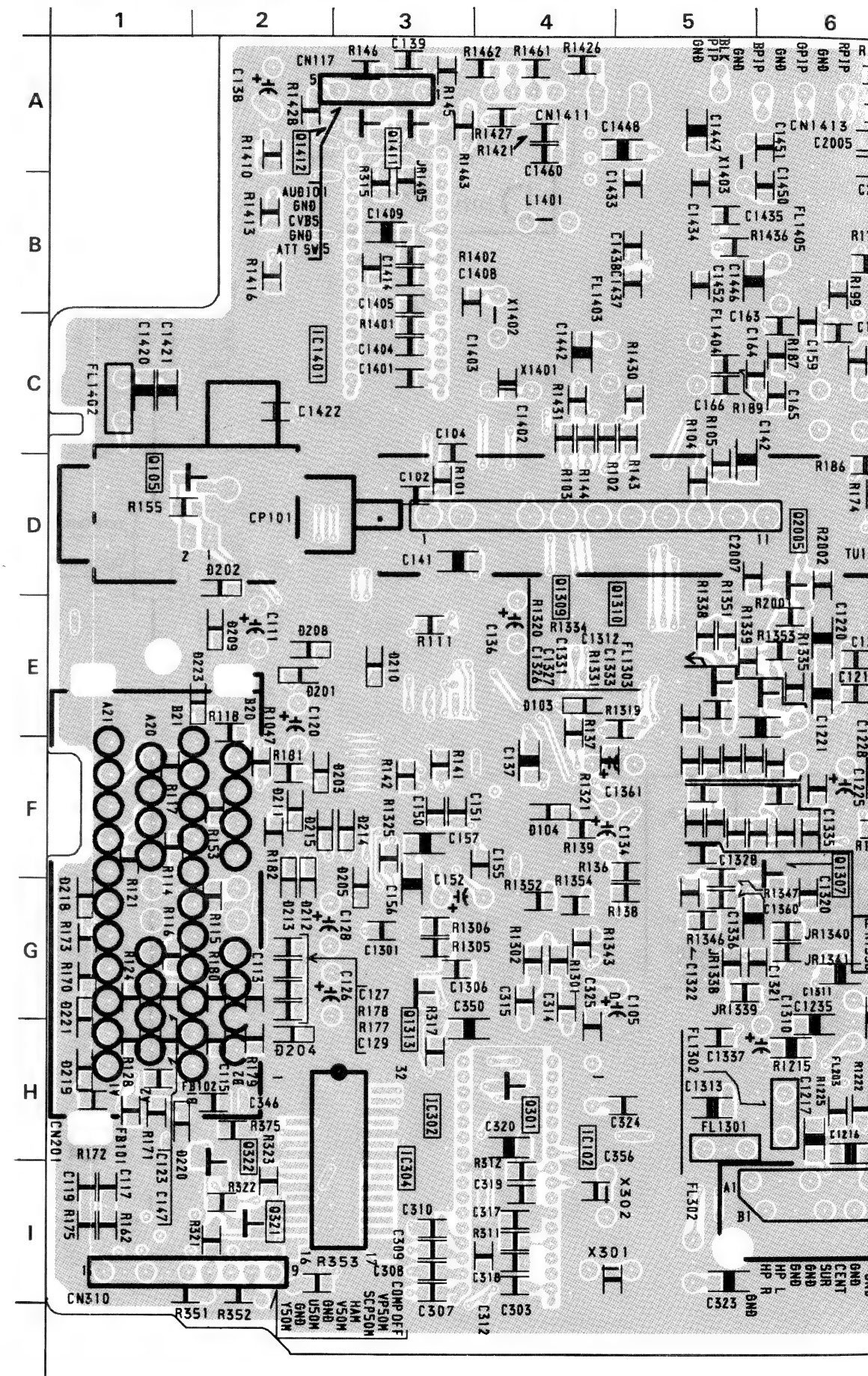

A Board < Component Side >

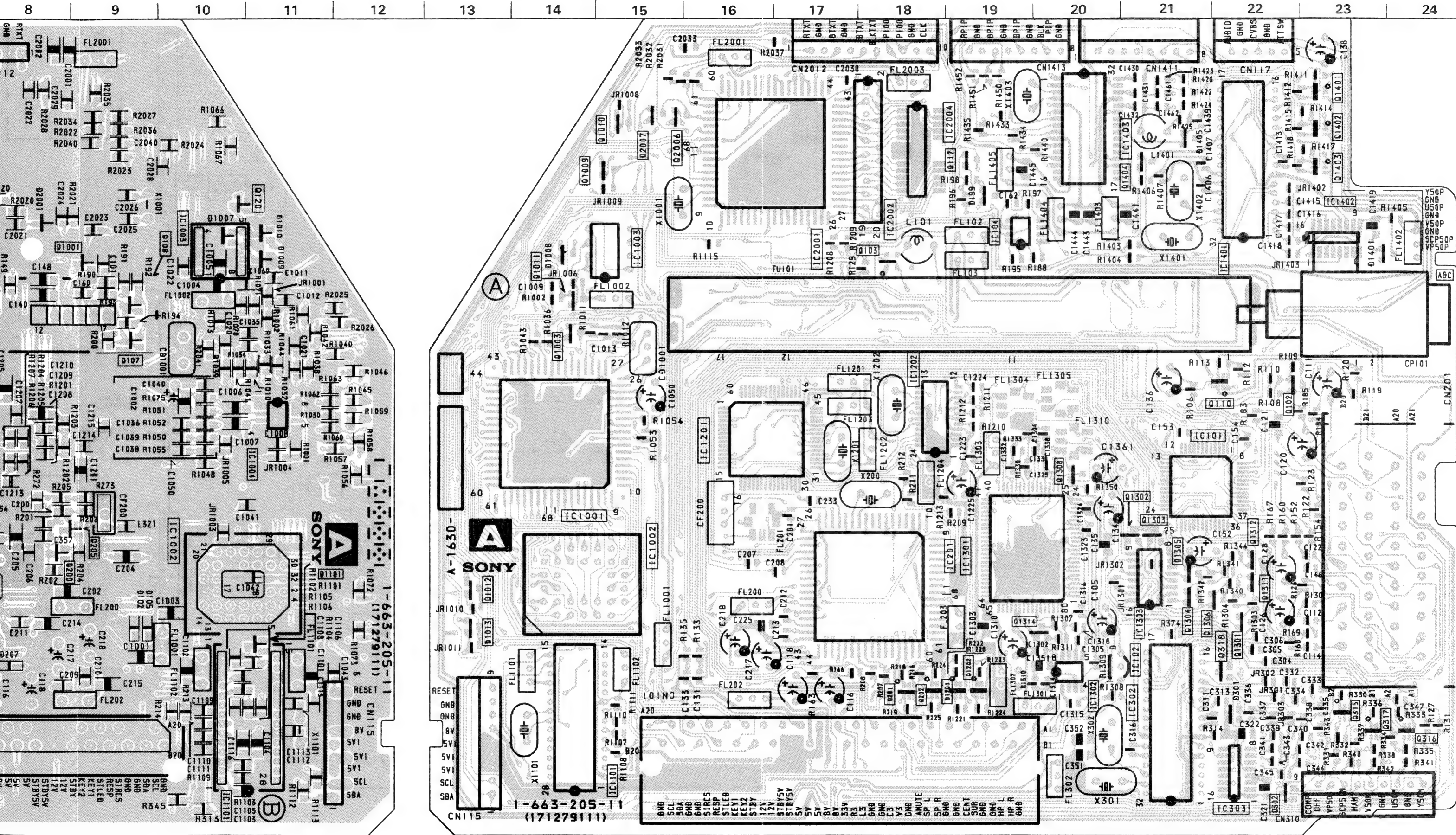

A B C D E F G H I J K L M N O

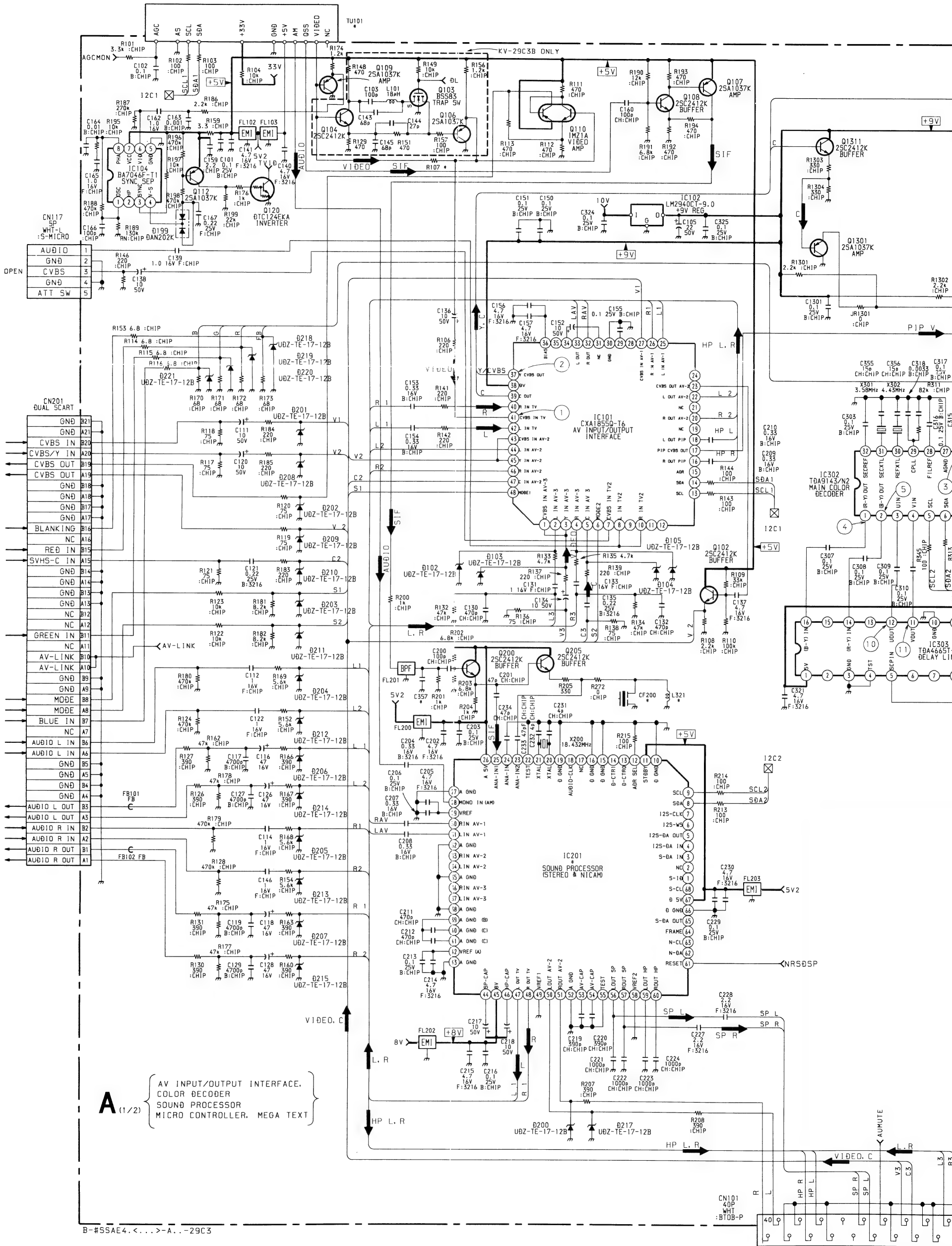

B-#SSAE4.<...>-A...-29C3

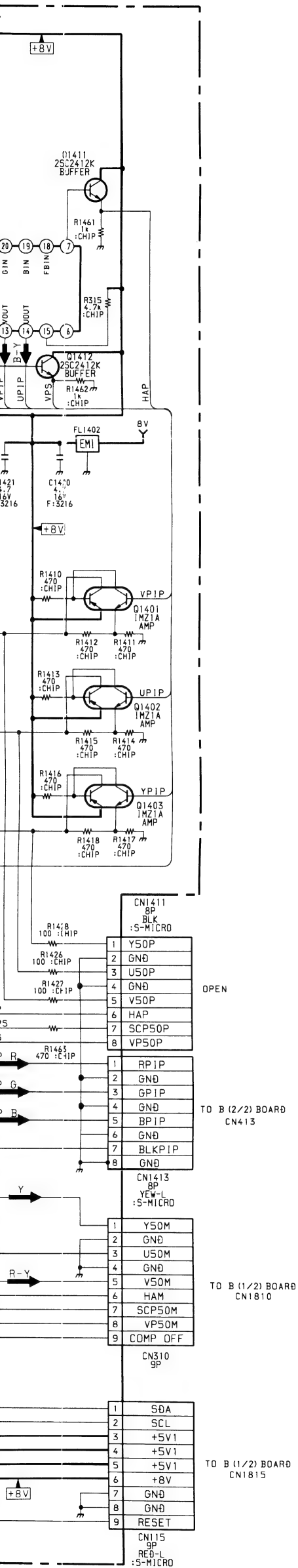

A (1/2) BOARD
TRANSISTOR VOLTAGE TABLE

Transistor Voltage Table			
Ref No	B Base	C Collector	E Emitter
Q102	1.9	4.7	1.3
Q105	0.08	4.5	0.08
Q107	4.4	1.7	5.0
Q108	1.8	4.4	1.2
Q112	4.3	4.9	5.0
Q120	4.6	0.1	0.1
Q301	0.5	8.0	0.4
Q302	-	8.0	0.3
Q318	0.1	5.2	0.1
Q1201	8.6	5.0	9.2
Q1202	0.7	5.0	9.2
Q1301	1.9	-	0.2
Q1302	-	-	0.6
Q1303	0.8	-	1.5
Q1304	2.2	-	0.1
Q1305	2.0	-	0.1
Q1306	1.7	-	-
Q1307	-	3.4	0.1
Q1308	3.5	4.7	2.9
Q1309	0.9	0.1	1.6
Q1310	1.0	0.1	1.6
Q1311	4.5	9.0	3.9
Q1312	4.5	9.0	-
Q1313	4.6	0.7	0.1
Q1314	4.8	4.7	4.3
Q1404	4.5	7.8	3.8
Q1411	0.5	8.0	0.6
Q1412	0.1	8.0	0.1
Q1201	2.6	8.6	2.1
Q1202	2.6	8.6	2.1

WAVEFORMS A BOARD

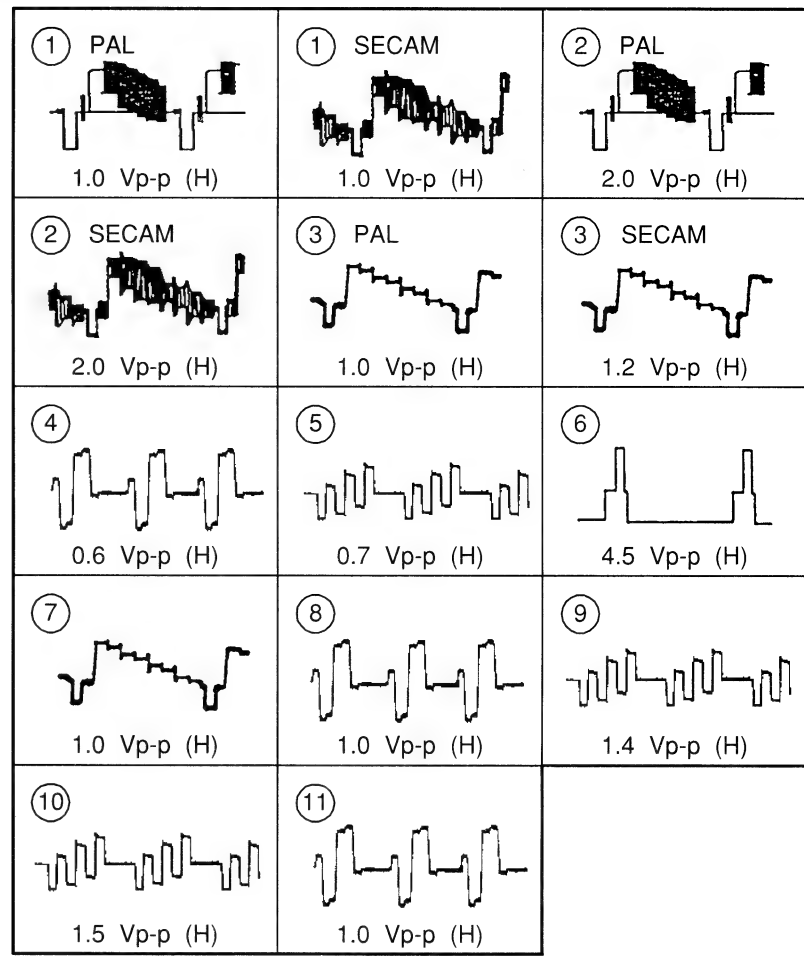

A (1/2) BOARD IC VOLTAGE TABLE

IC Voltage Table					
Ref No	Pin No	Voltage (V)	Ref No	Pin No	Voltage (V)
IC201	4	0.5	IC1201	4	4.7
	5-6	4.7		13	4.7
	7	2.4		31	4.7
	8-9	4.7		35	4.7
	20	2.4		37	2.7
	24	4.4		39	2.2
	25	8.8		40	2.7
	26	4.4		41	4.7
	28	3.8		45	4.8
	29	2.7		29	2.7
	30-31	3.8		30-31	3.8
	39-42	3.8		39-42	3.8
	44	6.2		44	6.2
	45	8.0		45	8.0
	46	7.0		1	5.0
	47-48	3.8		5	0.6
	50-51	3.7		11-12	3.0
	53-54	3.8		14	1.4
56-57	1.2	16	1.2		
61	4.8	1-2	2.0		
IC302	1-2	2.0	IC1401	3-4	2.4
	3-4	2.4		5	3.5
	5	3.0		6	4.0
	6	4.0		7	7.8
	7	8.0		8	5.0
	8	5.0		10	0.8
	10	0.5		12	2.4
	12	3.2		13-14	2.6
	13-14	2.6		15	8.0
	15	8.0		17	0.3
	17	0.3		22	7.8
	19	1.6		24	3.6
	21	1.0		26	3.3
	23-24	4.0		28	3.5
	26	3.7		29	4.3
	28	3.5		30	2.6
	29	5.0		31	2.6
	30	2.5		32	3.8
31	2.5				
32	2.0				

A BOARD * MARK

Model Ref. No.	29C3A	29C3B	29C3D	29C3E	29C3K	29C3R
C357	39PF	39PF	39PF	-	39PF	39PF
CF200	6.5MHz	6.5MHz	6.5MHz	-	6.5MHz	6.5MHz
IC201	MSP3400C-PP-C6-T-ND	MSP34103-PS-F7-T-ND	MSP3400C-PP-C6-T-ND	MSP3410B-PS-F7-T-ND	MSP3400C-PP-C6-T-ND	MSP3400C-PP-C6-T-ND
L321	10UH	10UH	10UH	-	10UH	10UH
TU101	TUVIF (AEP)	TUVIF (FR)	TUVIF (AEP)	TUVIF (AEP)	TUVIF (AEP)	TUVIF (AEP)

B-#SSAE4.<...>-A.-29C3

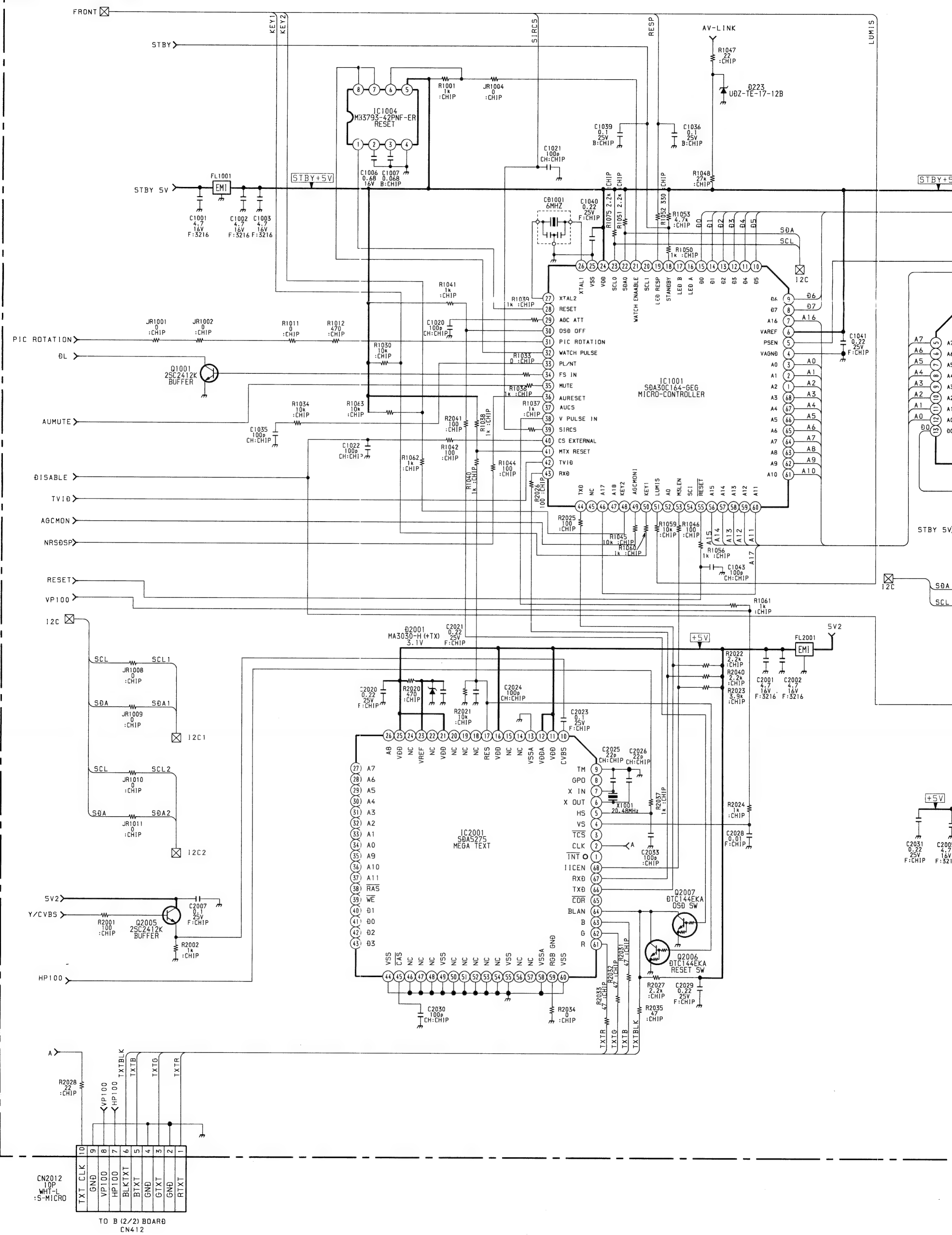

A (2/2)

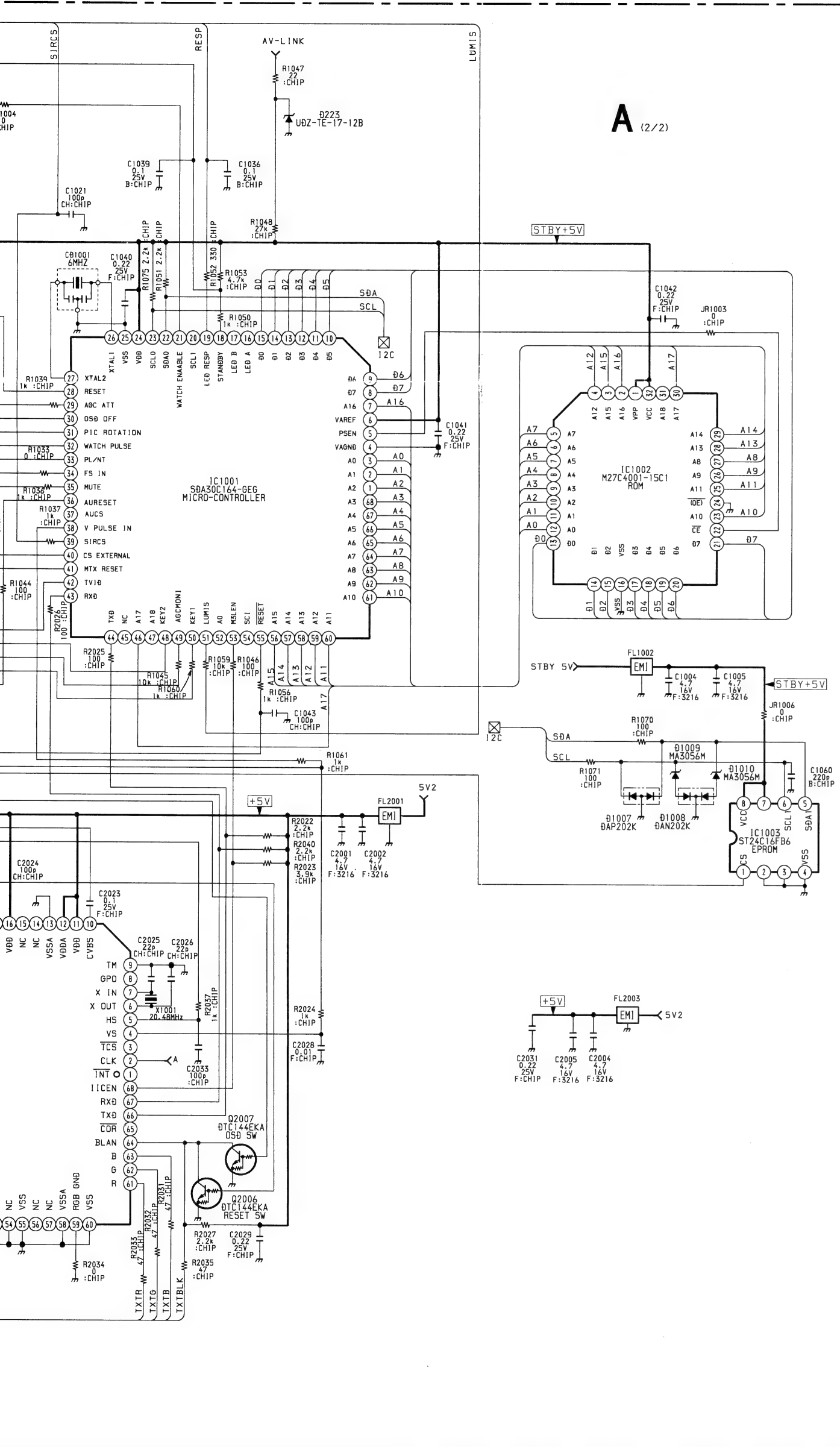

A (2/2) BOARD IC VOLTAGE TABLE

IC Voltage Table					
Ref No	Pin No	Voltage (V)	Ref No	Pin No	Voltage (V)
IC101	1-5	4.6	IC1101	1	4.8
	7-8	4.6		2	1.1
	10	4.6		4	0.9
	17	4.6		5	0.3
	23	4.6		6-7	2.4
	29	4.6		8	1.4
	31	4.6		9	4.7
	34	4.6		10	1.7
	36	4.6		11	1.5
	38	9.0		16	4.0
40-47	4.6	18-20	4.7		
IC1001	5	2.4	IC2001	21	2.5
	6	4.8		22	2.3
	19	3.6		2	0.4
	20	0.1		5	0.3
	24	4.8		6-7	1.6
	26	2.1		8	4.0
	27	2.3		10	1.0
	28	4.6		11-12	4.7
	30	0.1		16	4.7
	31-32	2.4		21	4.7
	33	4.8		23	2.9
	36	4.1		25	4.7
	38	0.1		66	4.7
	39	0.6		68	4.7
	40	4.8			
	41	0.1			
	42	4.8			
	43	4.4			
44	4.1				
48	4.8				
49	2.2				
50	4.8				
52	4.8				
54	4.8				

A (2/2) BOARD TRANSISTOR VOLTAGE TABLE

Transistor Voltage Table				
Ref No	B Base	C Collector	E Emitter	
Q1001	0.1	0.7	0.1	
Q1004	0.1	0.7	-	
Q1101	3.3	5.0	2.6	

WAVEFORMS C BOARD

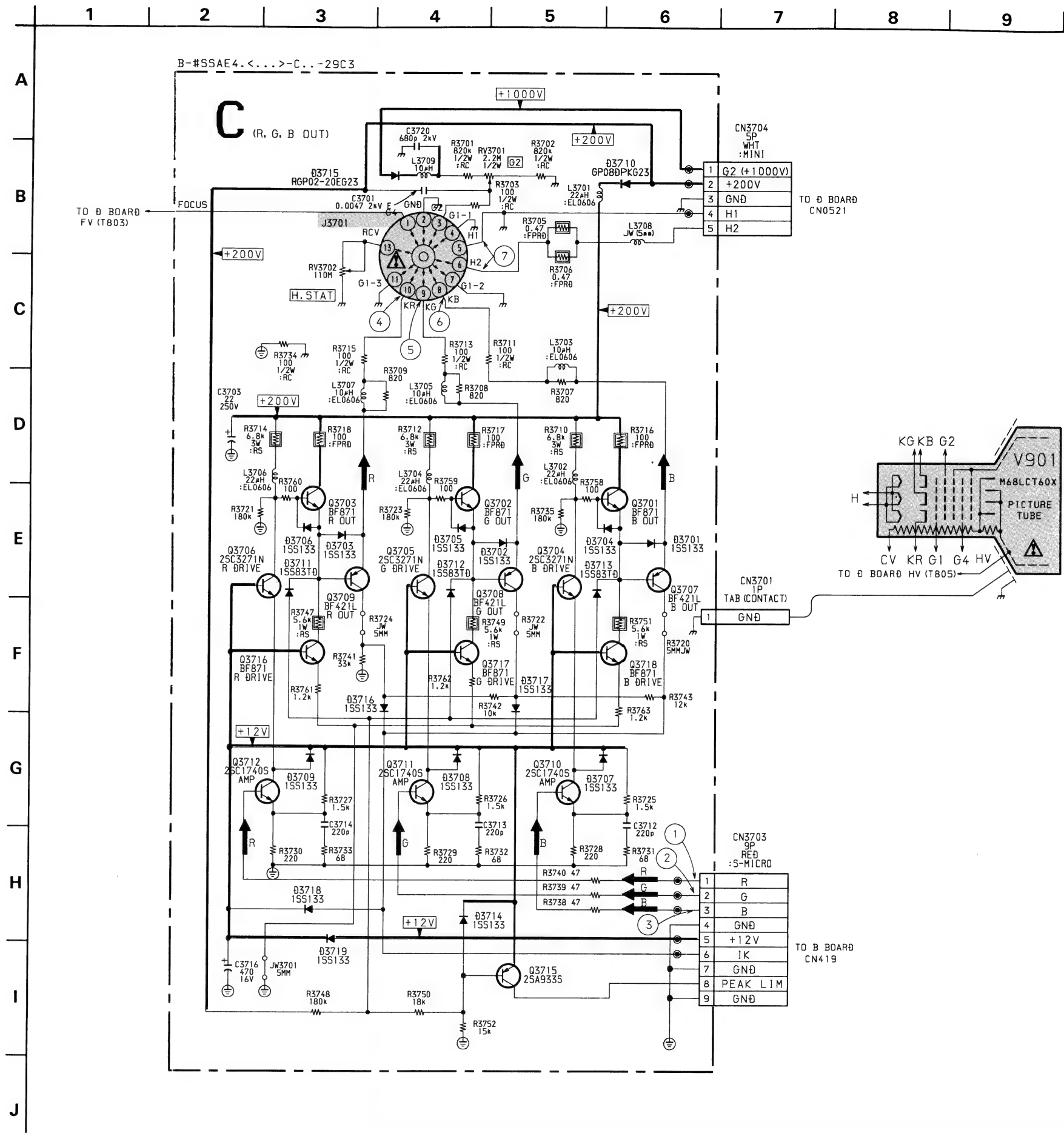
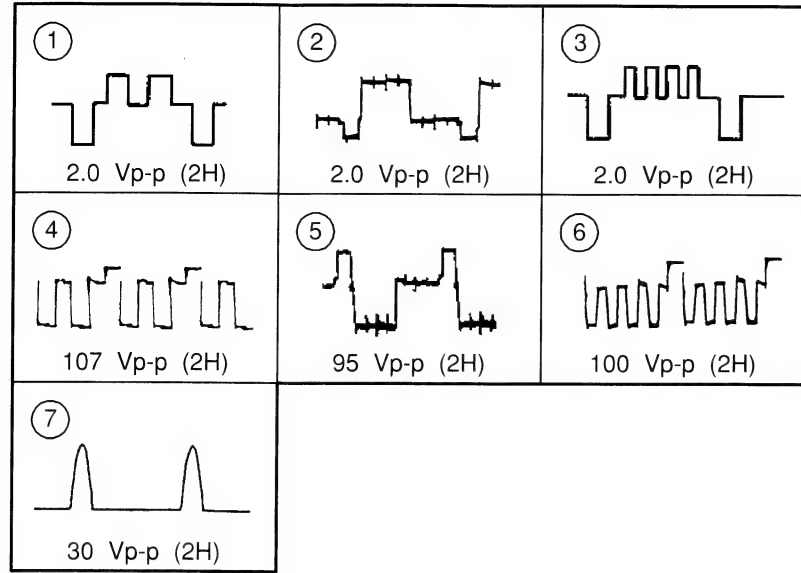

C Board

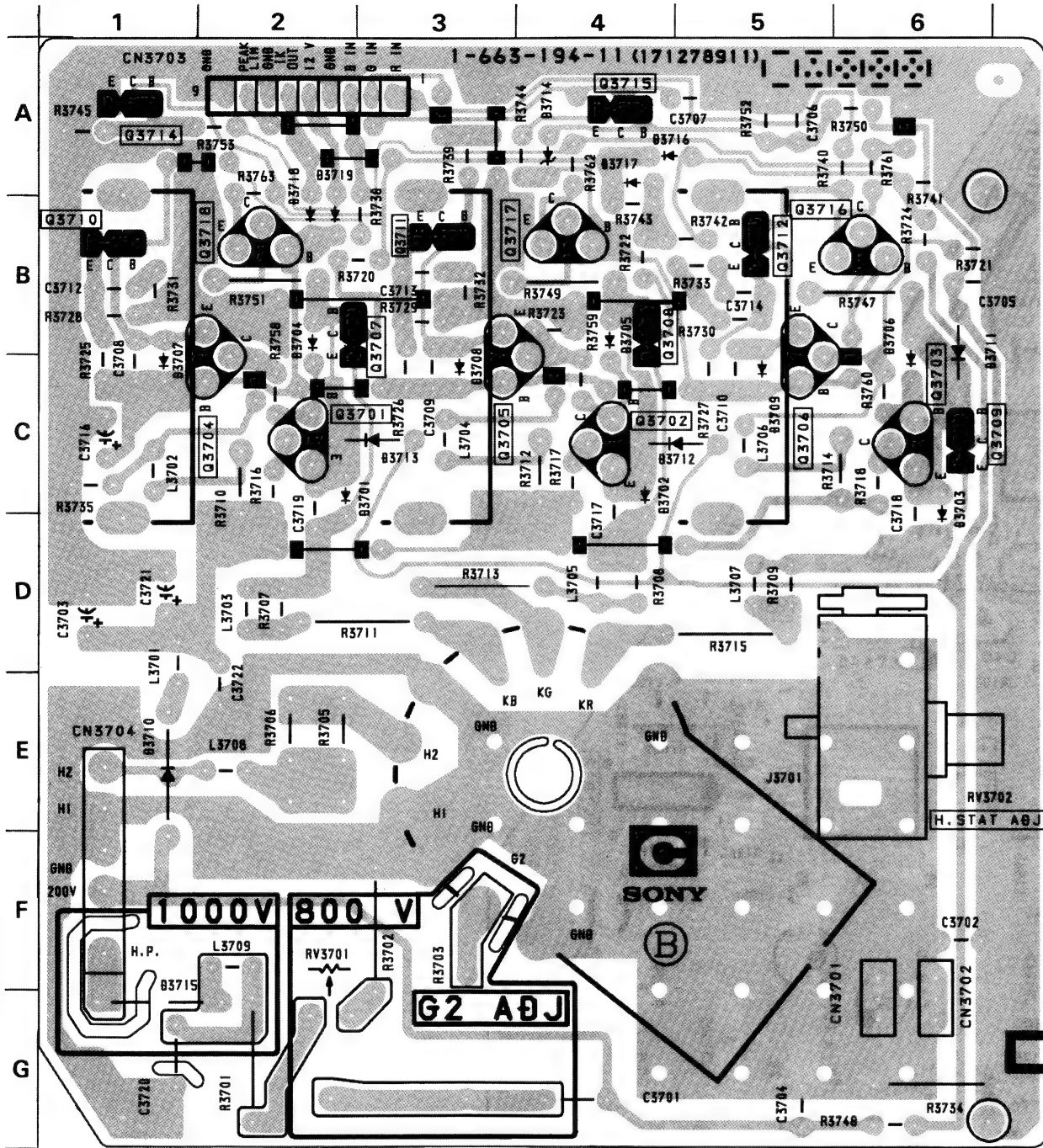

C BOARD

TRANSISTOR	
Q3701	C-2
Q3702	C-4
Q3703	C-6
Q3704	C-2
Q3705	C-3
Q3706	C-5
Q3707	B-3
Q3708	B-4
Q3709	C-6
Q3710	B-1
Q3711	B-3
Q3712	B-5
Q3715	A-4
Q3716	B-6
Q3717	B-4
Q3718	B-2

DIODE	
D3701	C-2
D3702	C-4
D3703	D-6
D3704	B-2
D3705	B-4
D3706	B-6
D3707	C-1
D3708	C-3
D3709	C-5
D3710	E-1
D3711	B-6
D3712	C-5
D3713	C-3
D3714	A-4
D3715	G-1
D3716	A-5
D3717	A-4
D3718	A-2
D3719	A-2

VARIABLE RESISTOR	
RV3701	F-2
RV3702	E-6

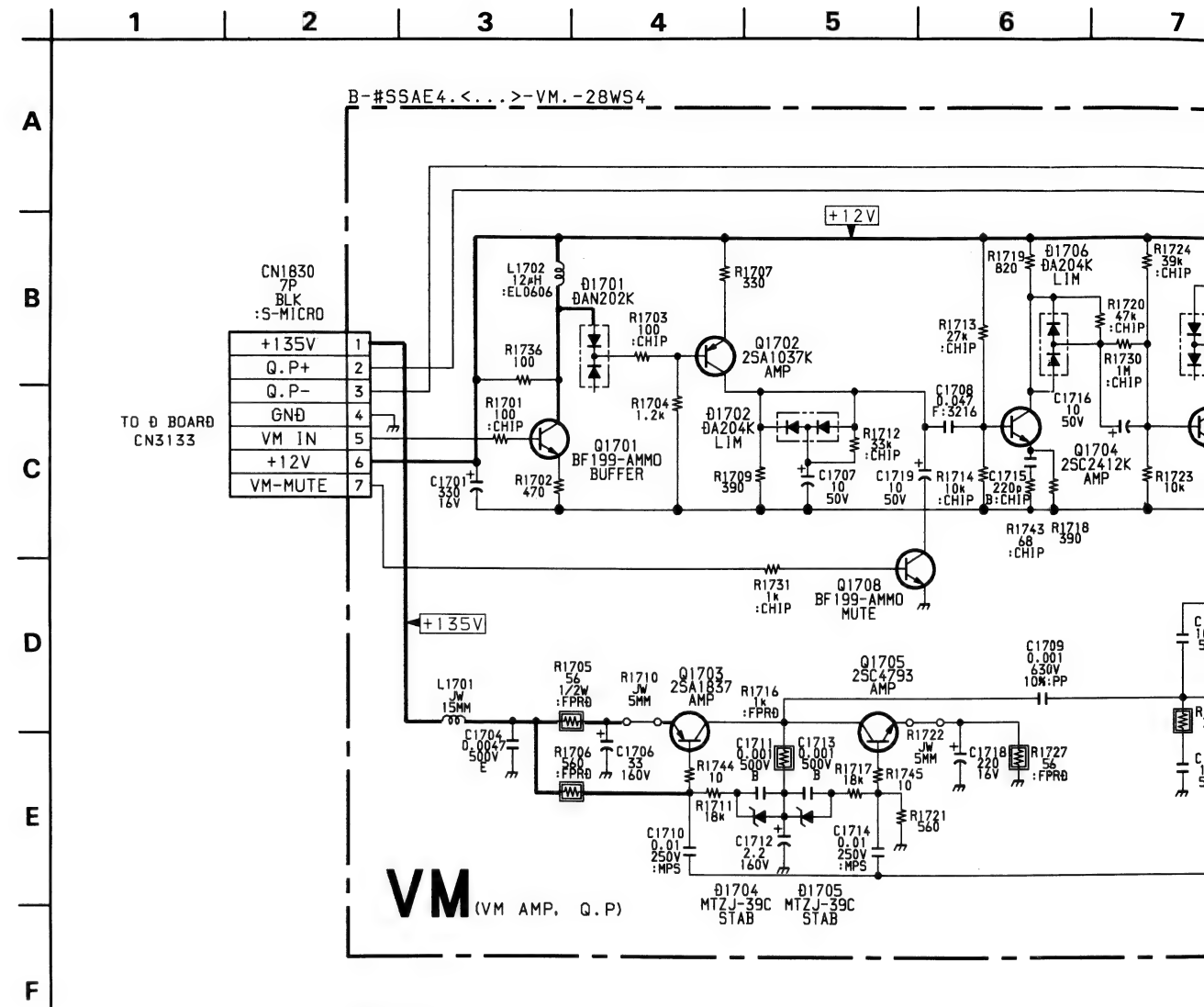

VM BOARD TRANSISTOR VOLTAGE TABLE

Transistor Voltage Table			
Ref No	B Base	C Collector	E Emitter
Q1701	0.8	0.7	2.1
Q1702	1.8	0.2	1.9
Q1703	24.0	13.3	24.0
Q1704	0.5	1.2	0.4
Q1705	0.1	12.3	-
Q1706	0.4	1.1	0.3
Q1707	1.5	2.1	1.4
Q1708	-	-	-
Q1710	1.1	-	1.2
Q1711	1.4	2.1	1.3
Q1712	1.3	1.2	-

6 7 8 9 10 11 12

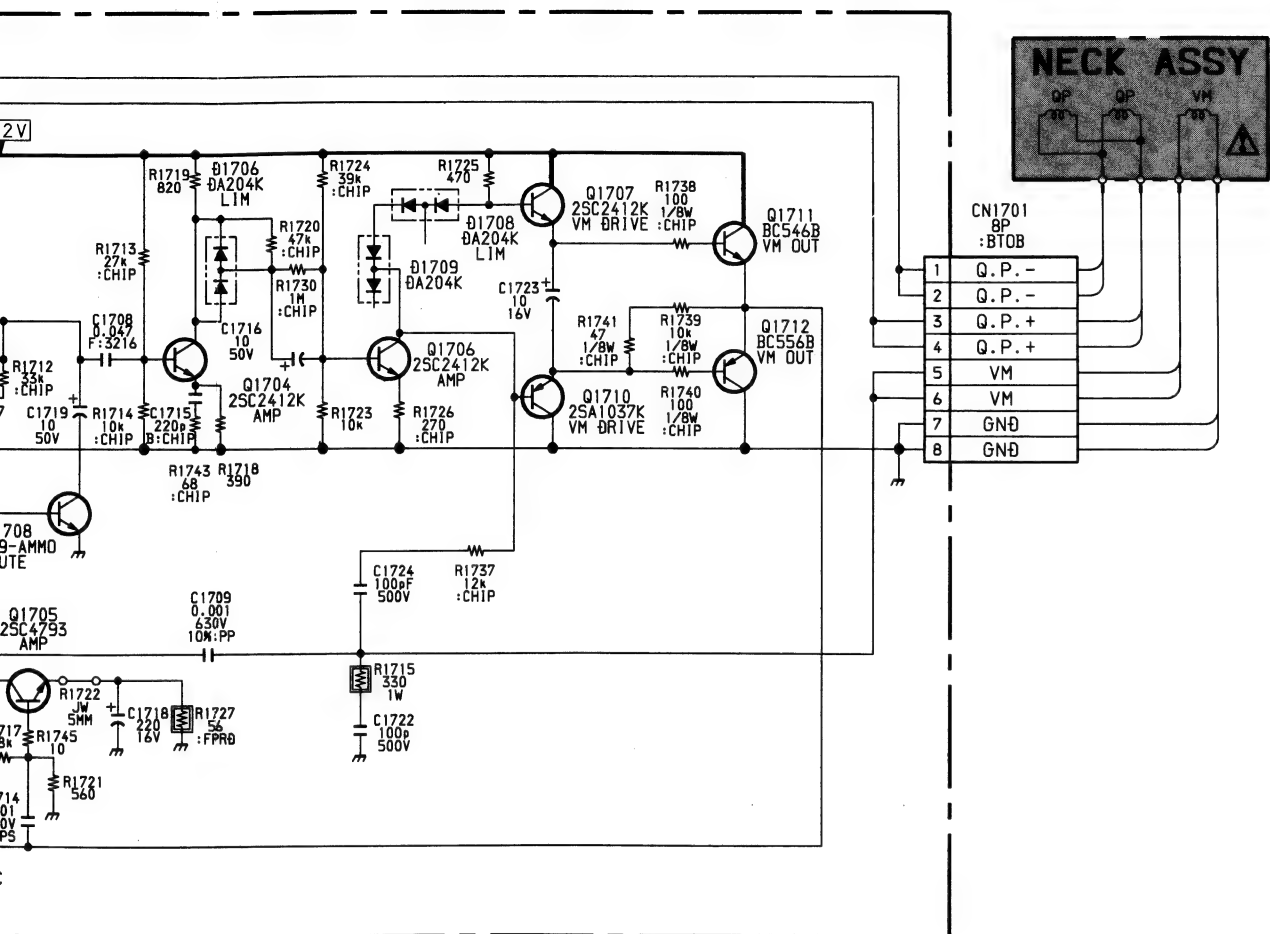

VM Board

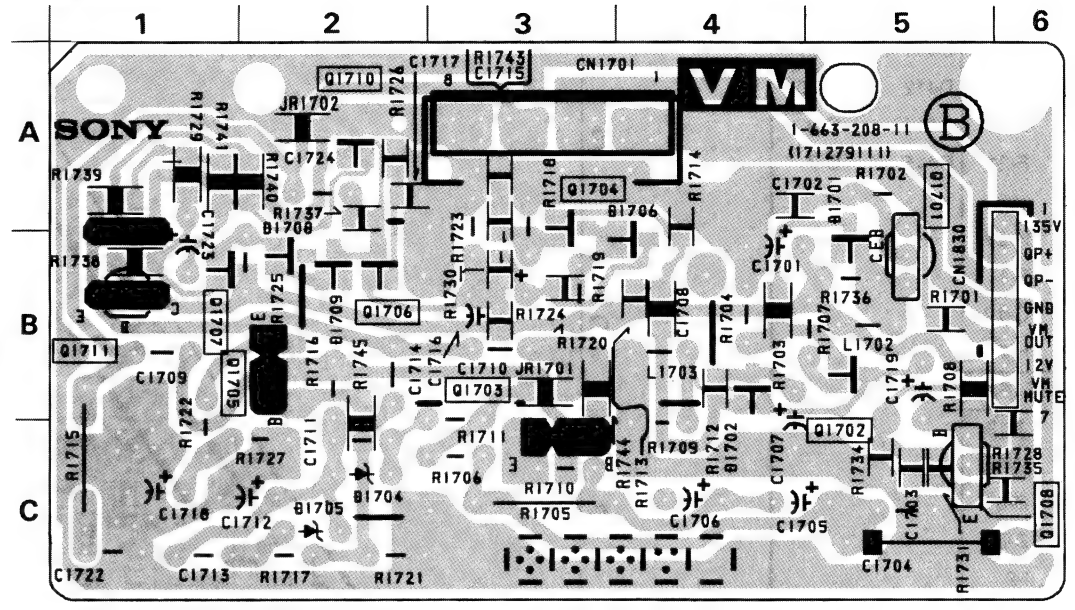

VM BOARD

TRANSISTOR	
Q1701	A-5
Q1702	C-5
Q1703	B-3
Q1704	A-3
Q1705	B-2
Q1706	B-2
Q1707	B-1
Q1708	C-6
Q1710	A-2
Q1711	B-1
Q1712	A-1

DIODE	
D1701	A-5
D1702	C-4
D1704	C-2
D1705	C-2
D1706	A-4
D1708	B-2
D1709	B-2

B BOARD

IC		DIODE	
IC402	C-6	D401	D-5
IC403	D-20	D402	C-3
IC1801	G-13	D403	C-3
IC1802	H-16	D410	B-20
IC1803	I-17	D411	A-21
IC1809	E-15	D412	A-20
IC1812	F-24	D414	C-9
IC1814	F-21	D415	B-7
TRANSISTOR			
Q415	A-19		
Q416	B-20		
Q1801	C-8		
Q1802	D-8		
Q1804	I-2		
Q1805	H-10		
Q1808	H-2		
Q1809	E-7		
Q1810	I-23		
Q1812	C-8		

B Board < Conductor Side >

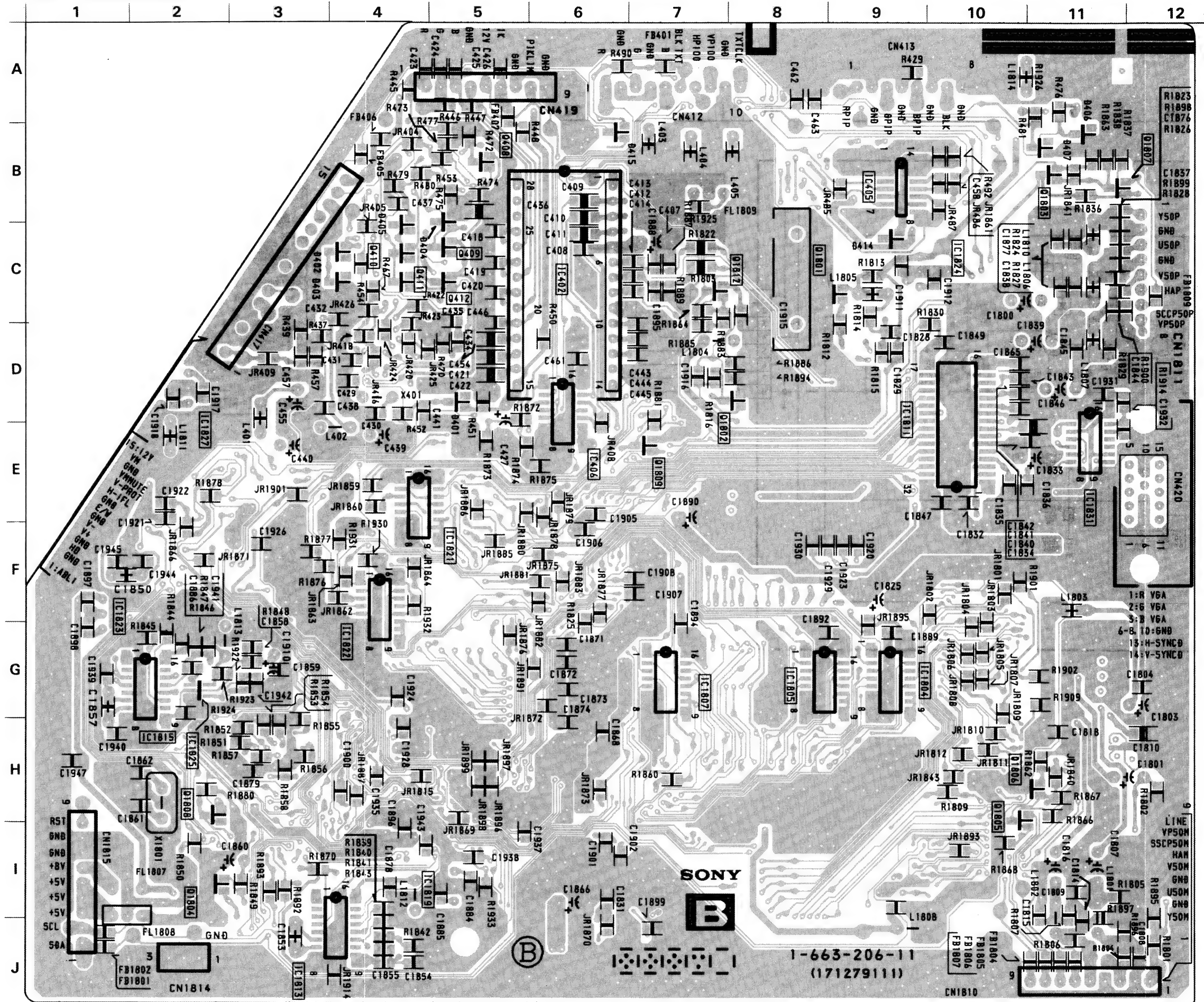

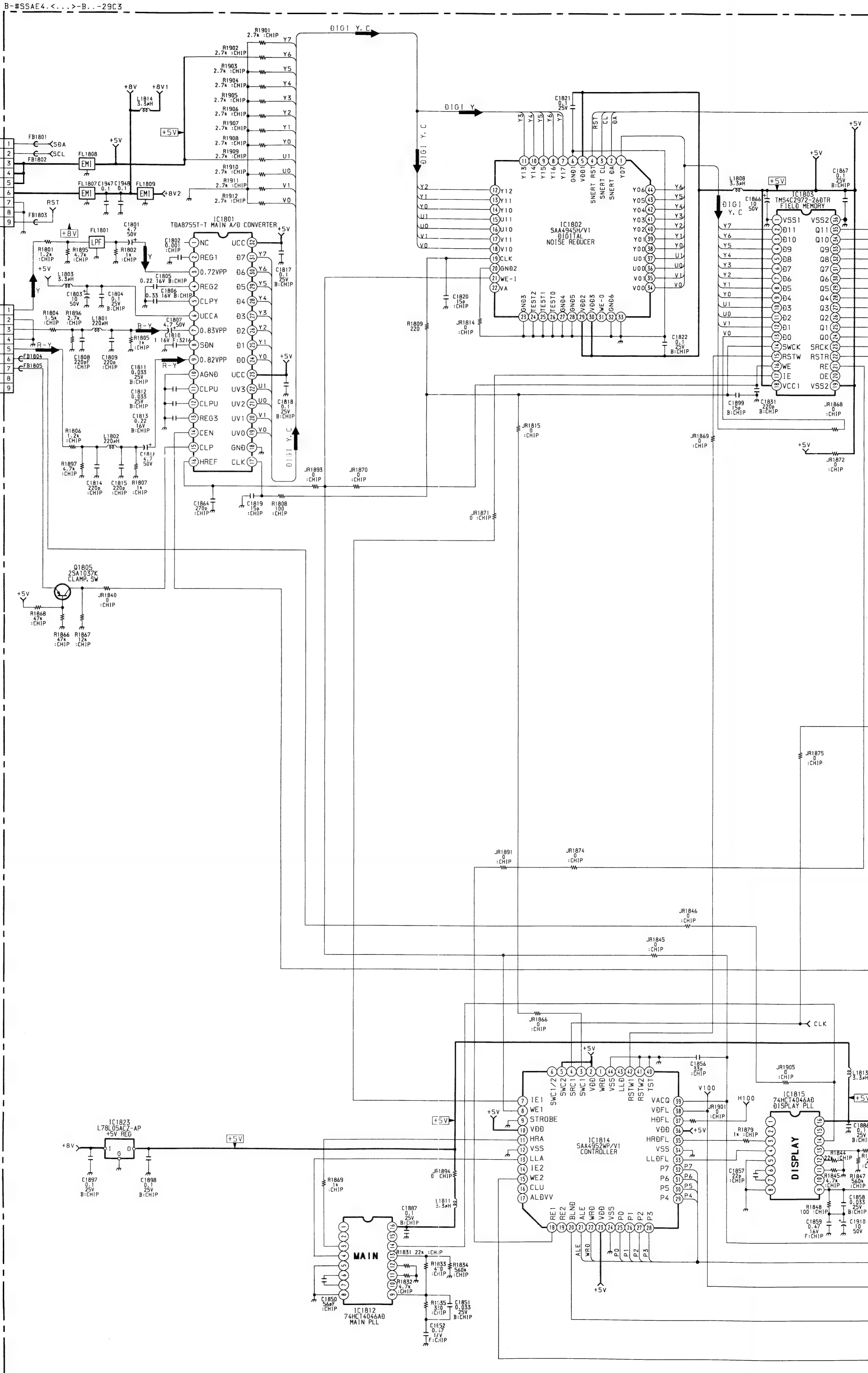

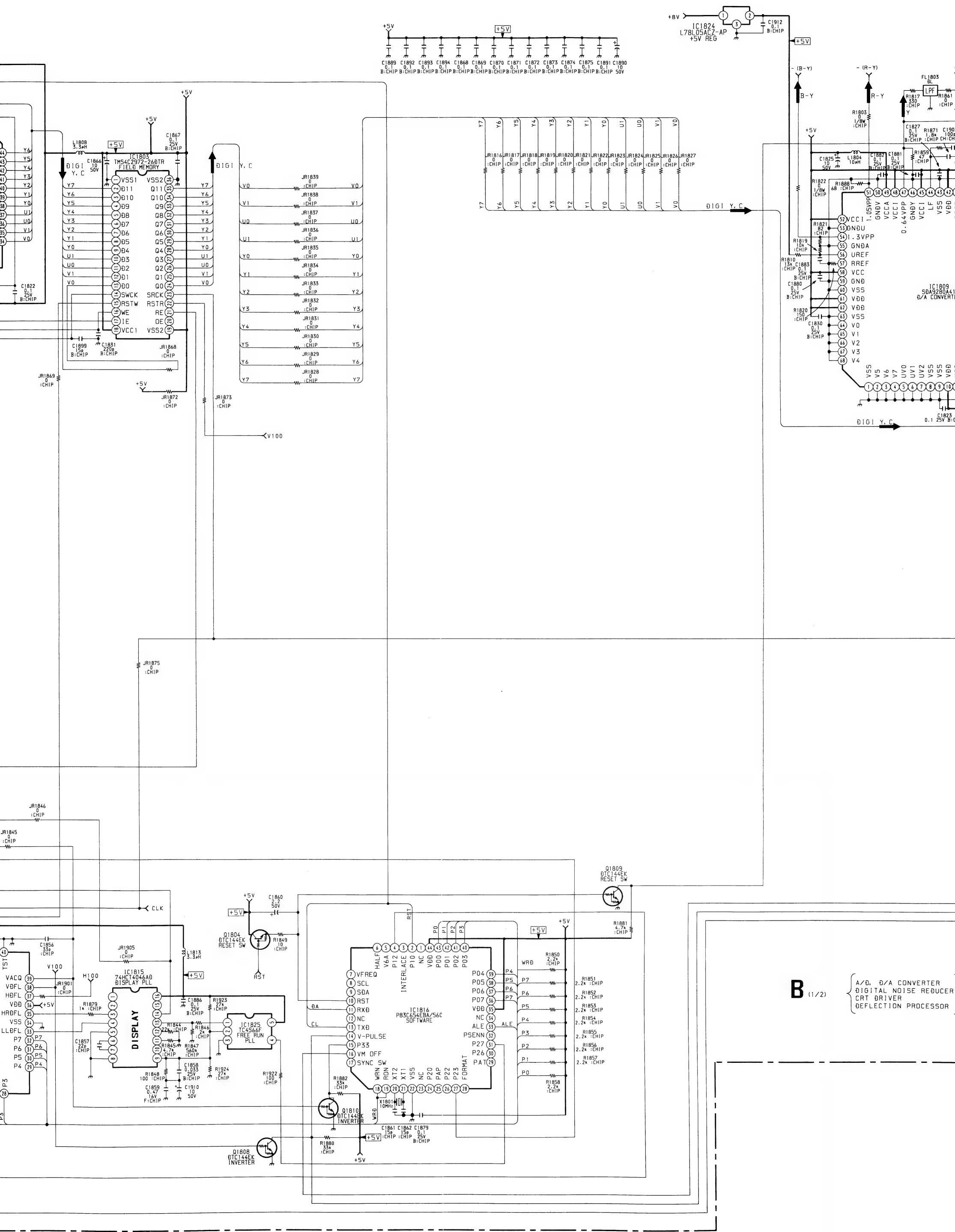

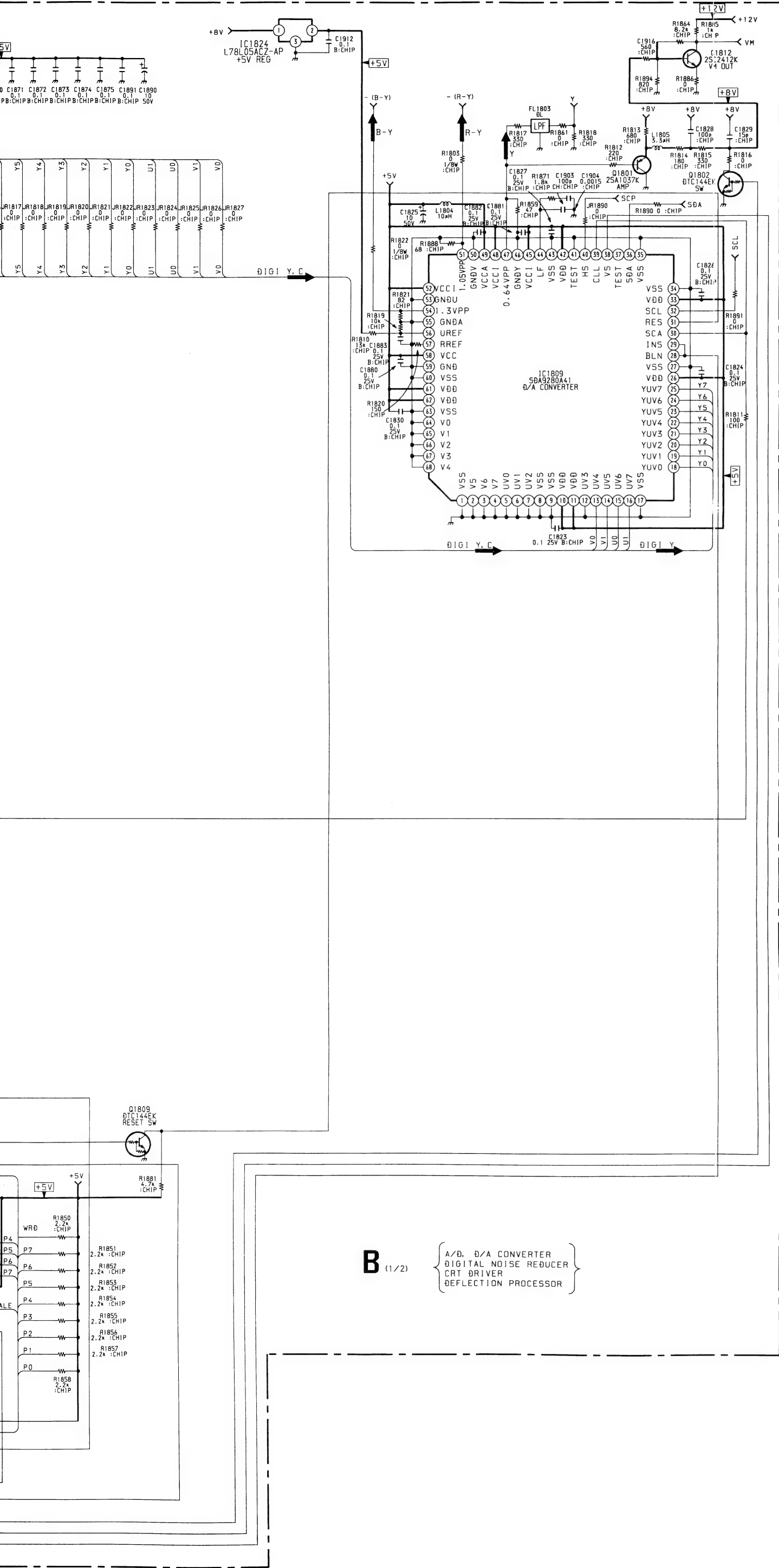

**B BOARD
TRANSISTOR VOLTAGE TABLE**

Transistor Voltage Table			
Ref No	B Base	C Collector	E Emitter
Q411	0.1	4.8	4.8
Q412	0.1	4.8	4.8
Q415	1.8	0.1	-
Q416	0.1	5.6	-
Q1801	0.1	-	0.9
Q1802	4.0	0.1	0.1
Q1804	0.3	4.8	0.1
Q1805	2.5	1.3	0.7
Q1807	2.5	1.3	0.7
Q1808	0.1	4.7	0.1
Q1809	0.1	0.1	0.1
Q1810	0.1	4.8	-
Q1812	0.5	10.5	-
Q1813	0.1	3.7	0.1

**B (1/2) BOARD
IC VOLTAGE TABLE**

IC Voltage Table		
Ref No	Pin No	Voltage (V)
IC1812	3-4	2.4
	6-7	0.7
	9	4.6
	11-13	4.7
	14	0.3
IC1813	3-4	2.4
	6-7	0.7
	9	4.6
	11-13	4.7
IC1815	14	0.3
	16	5.0
	1	5.0
	2	2.3
	3-4	2.5
	6-7	0.8
	9-11	3.0
IC1821	12	4.5
	13	3.0
	14	0.4
	15	0.2
	16	5.2
	2	2.5
IC1822	4-5	2.3
	12	2.0
	14	2.0
	15	2.6
	16	8.0

**B (2/2) BOARD
IC VOLTAGE TABLE**

IC Voltage Table		
Ref No	Pin No	Voltage (V)
IC402	2-4	5.0
	5	7.8
	6-7	4.0
	8	3.7
	10-12	5.0
	14	0.7
	16	4.7
	17	5.1
	18	1.8
	19	7.5
	20	2.5
	21	3.3
IC405	5	3.2
	9	3.2
	13-14	3.2
IC406	16	4.8

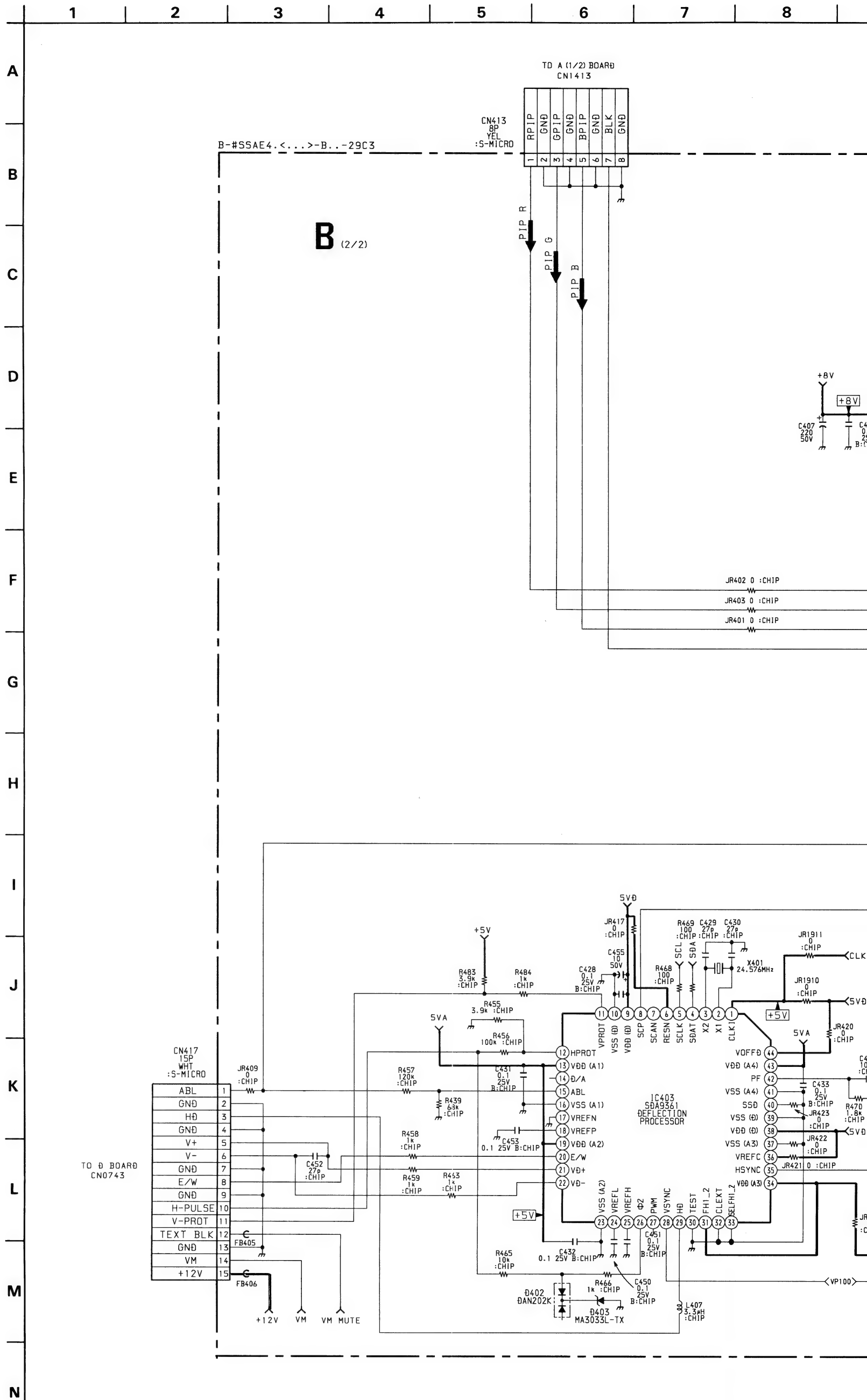

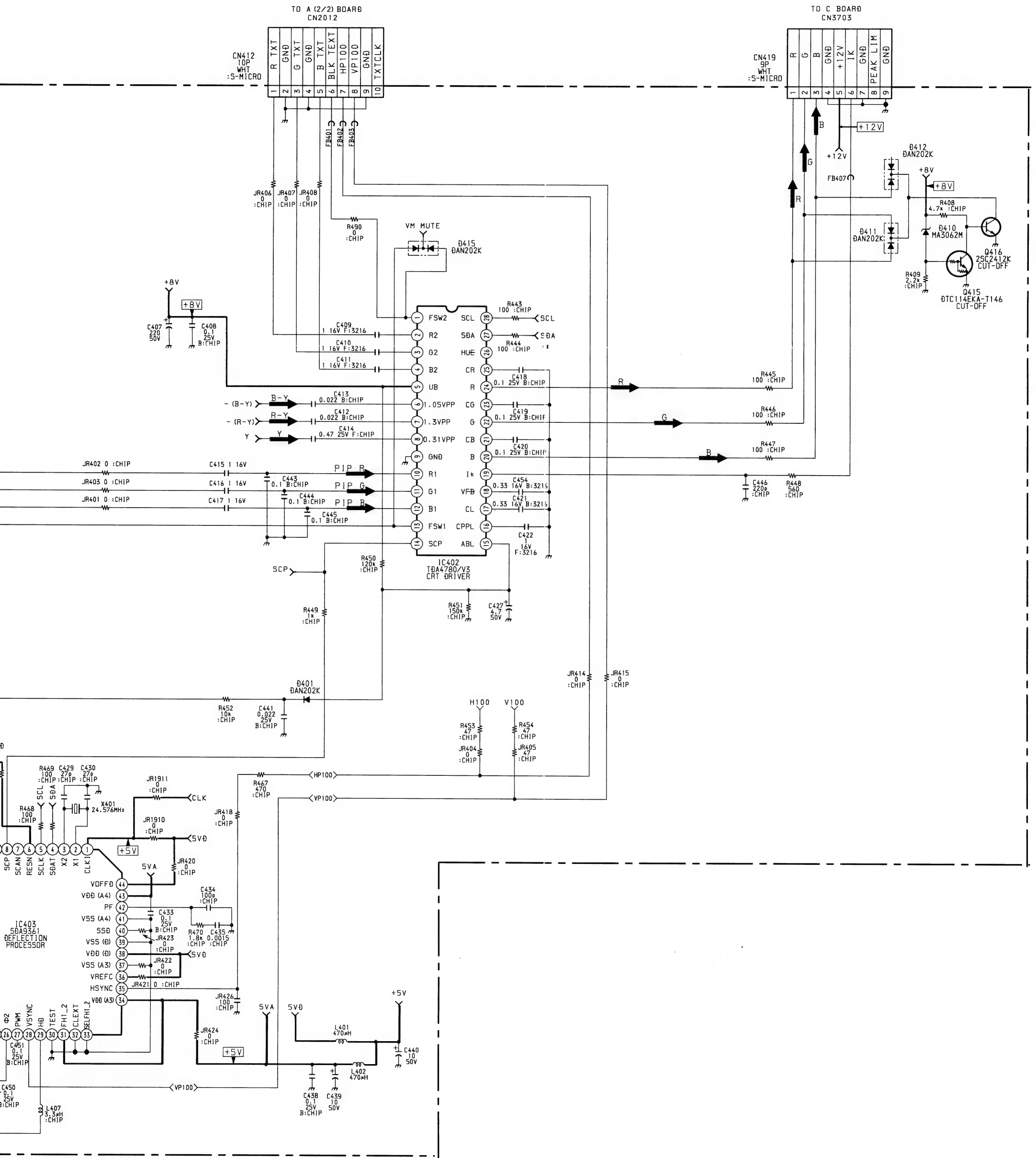

A
B
C
D
E
F
G
H
I

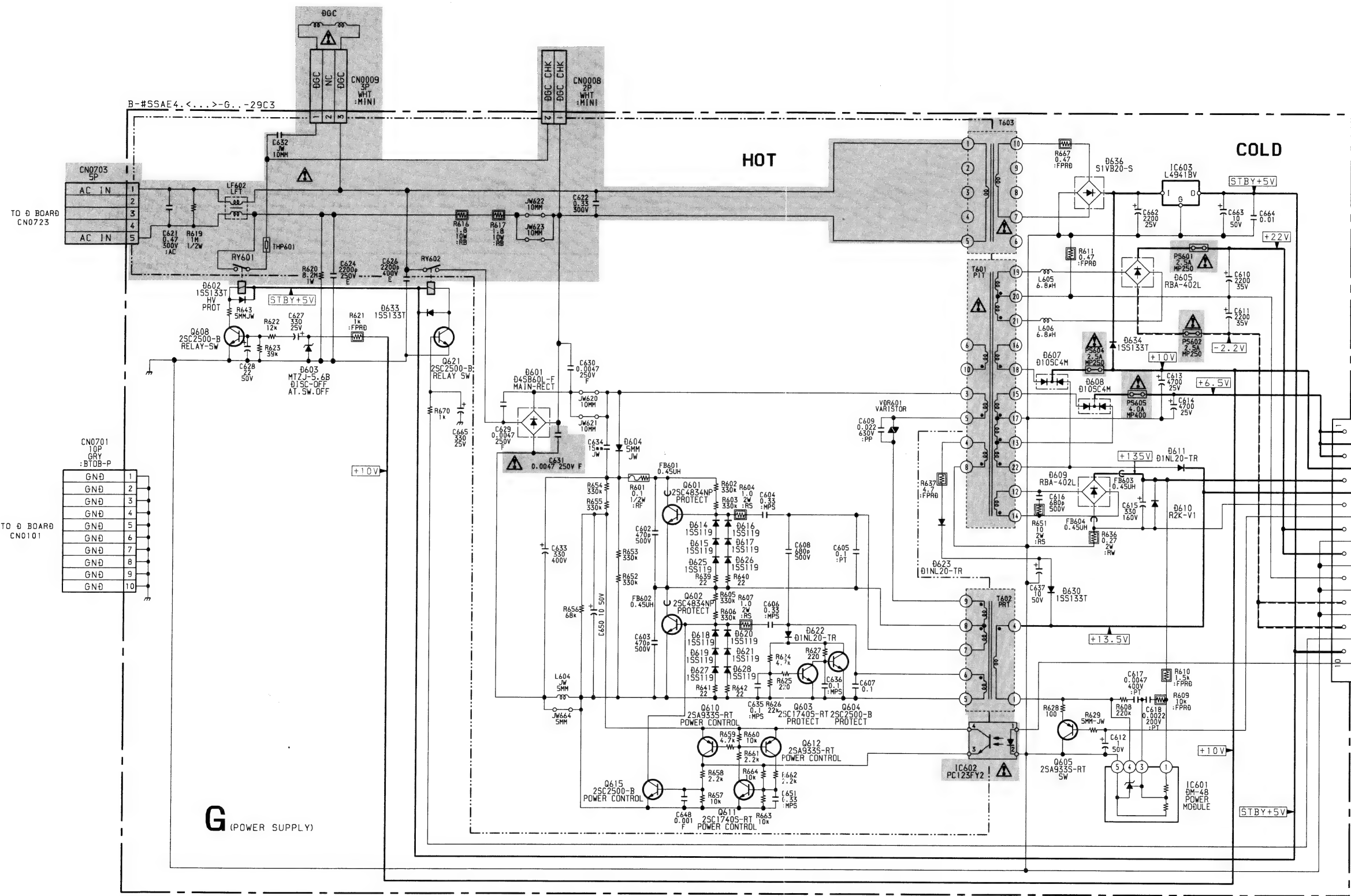

**G BOARD
TRANSISTOR VOLTAGE TABLE**

Transistor Voltage Table			
Ref No	B Base	C Collector	E Emitter
Q601	-1.6	-	-
Q602	0.2	293.0	-
Q603	0.6	0.1	-
Q604	0.1	1.4	-
Q605	0.1	11.0	-0.1
Q608	-	4.8	-0.1
Q610	22.0	-2.3	26.8
Q611	-1.6	26.6	-
Q612	26.7	-1.1	26.8
Q615	-2.6	-1.5	-
Q621	0.6	-	-0.1

- TO BOARD CN0702 B-T0-B
- ① 6.5V
 - ② 6.5V
 - ③ 10V
 - ④ 13.5V (KICK)
 - ⑤ GND (PROTECT)
 - ⑥ SOFT START
 - ⑦ +22V (AUD10)
 - ⑧ GND
 - ⑨ +22V (AUD10)
 - ⑩ GND (AUD10)
 - ⑪ GND
 - ⑫ -22V (AUD10)
 - ⑬ STB 5V
 - ⑭ PROTECT

TO BOARD CN0102

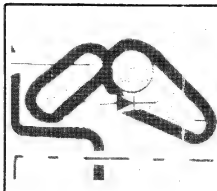

NOTE:
The circuit indicated as left contains high voltage of over 600 Vp-p. Care must be paid to prevent an electric shock in inspection or repairing.

G [POWER SUPPLY]

G Board

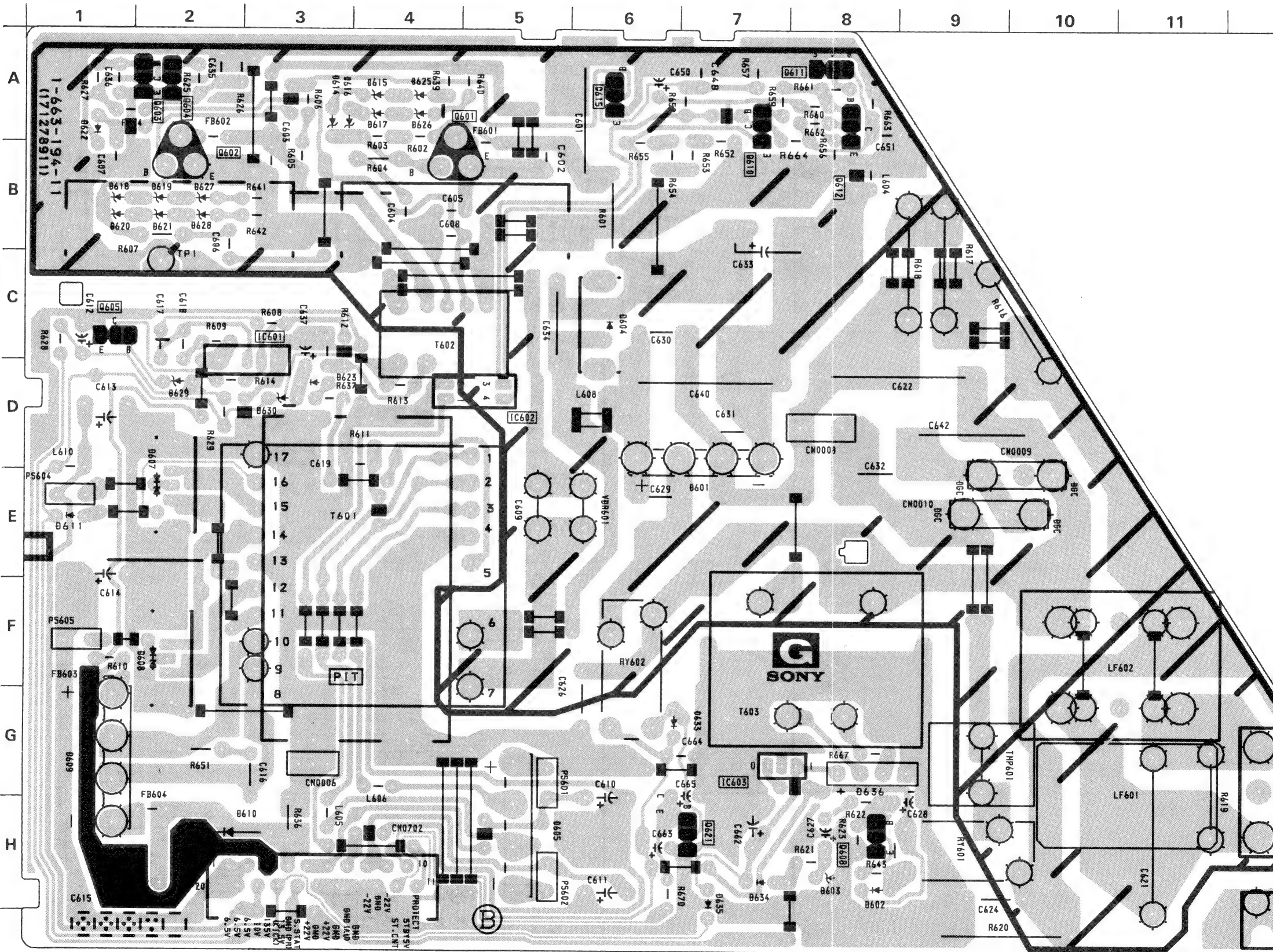

G BOARD

IC	
IC601	C-3
IC602	D-5
IC603	G-7
TRANSISTOR	
Q601	A-5
Q602	B-2
Q603	B-2
Q604	B-2
Q605	C-1
Q608	H-8
Q610	B-7
Q611	A-8
Q612	B-8
Q615	A-6
Q621	H-7
DIODE	
D601	E-7
D602	H-8
D603	H-8
D605	H-5
D607	E-2
D608	F-2
D609	G-1
D610	H-3
D611	E-1
D614	A-3
D615	A-4
D616	A-3
D617	A-4
D618	B-1
D619	B-2
D620	B-1
D621	B-2
D622	A-1
D623	D-3
D625	A-4
D626	A-4
D627	B-2
D628	B-2
D630	D-3
D633	G-7
D634	H-7
D636	G-8

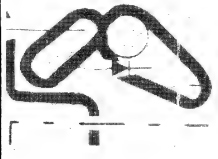

NOTE:
The circuit indicated as left contains high voltage of over 600 Vp-p. Care must be paid to prevent an electric shock in inspection or repairing.

PLY]

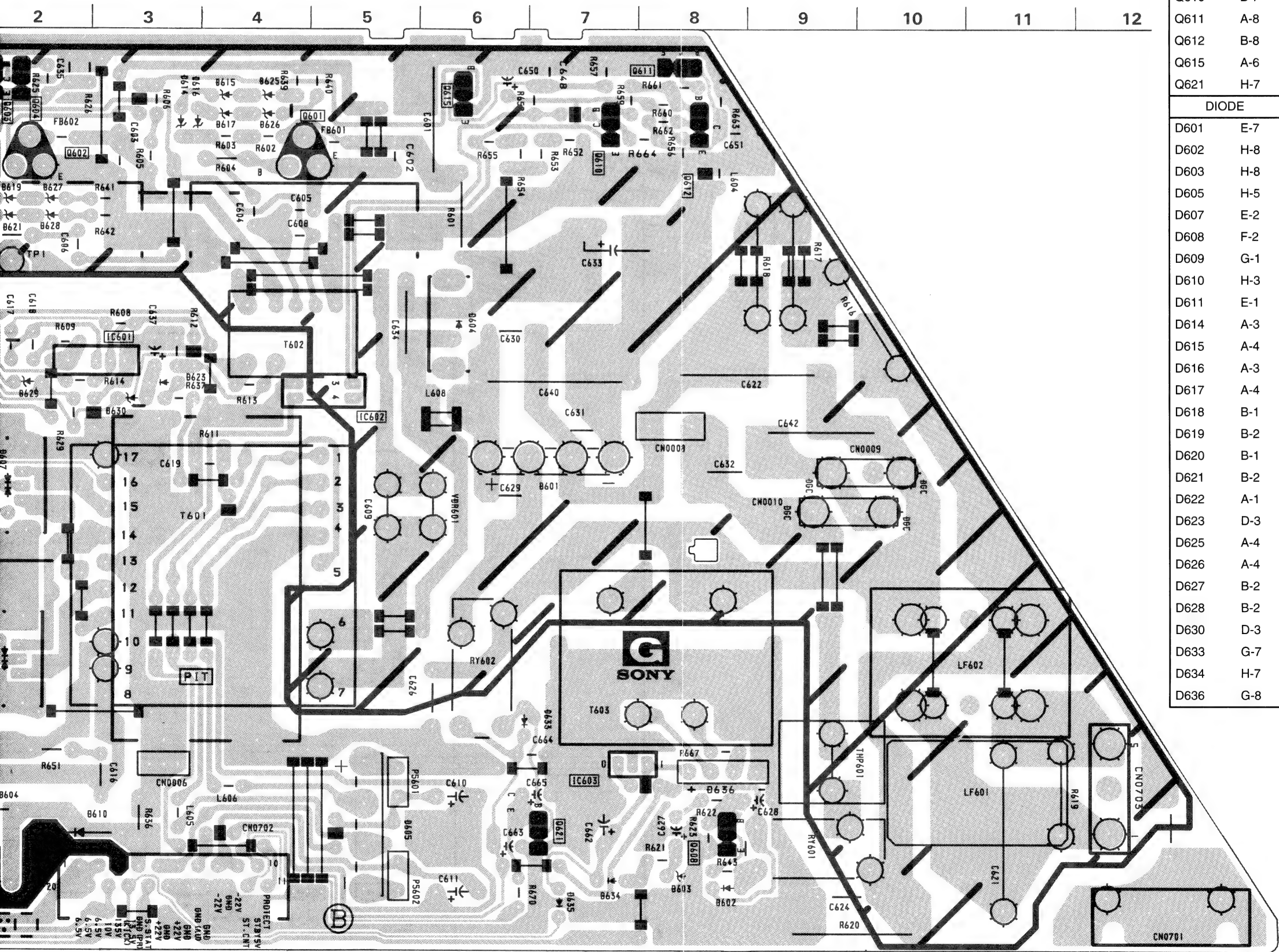

WAVEFORMS D BOARD

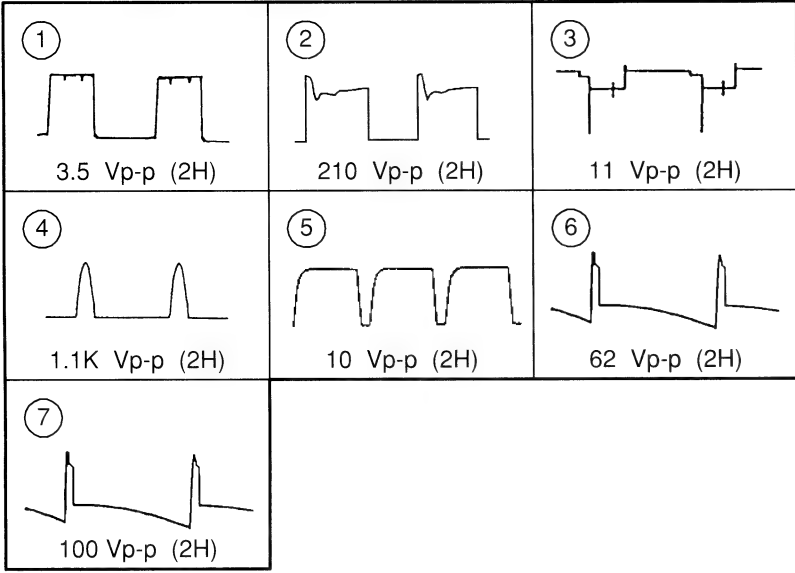

D BOARD
TRANSISTOR VOLTAGE TABLE

Transistor Voltage Table			
Ref No	B Base	C Collector	E Emitter
Q276	0.7	4.0	-
Q277	10.0	-	9.7
Q278	-1.3	-	-
Q279	-1.3	-	-1.3
Q280	0.4	0.7	-
Q281	0.7	-	-
Q282	0.7	-	-
Q801	-1.0	101.0	-
Q802	-	136.0	-
Q803	9.0	15.0	-
Q804	11.3	0.1	-1.3
Q606	0.5	4.8	0.3
Q607	4.8	1.6	4.8
Q613	13.5	-	-
Q614	10.0	9.0	10.0
Q616	0.7	-	-
Q617	0.7	3.5	-
Q618	3.5	-	-
Q620	-	10.0	-
Q624	-	10.0	-
Q2701	-	2.3	-
Q1610	-0.5	2.2	-
Q1611	0.2	43.4	-

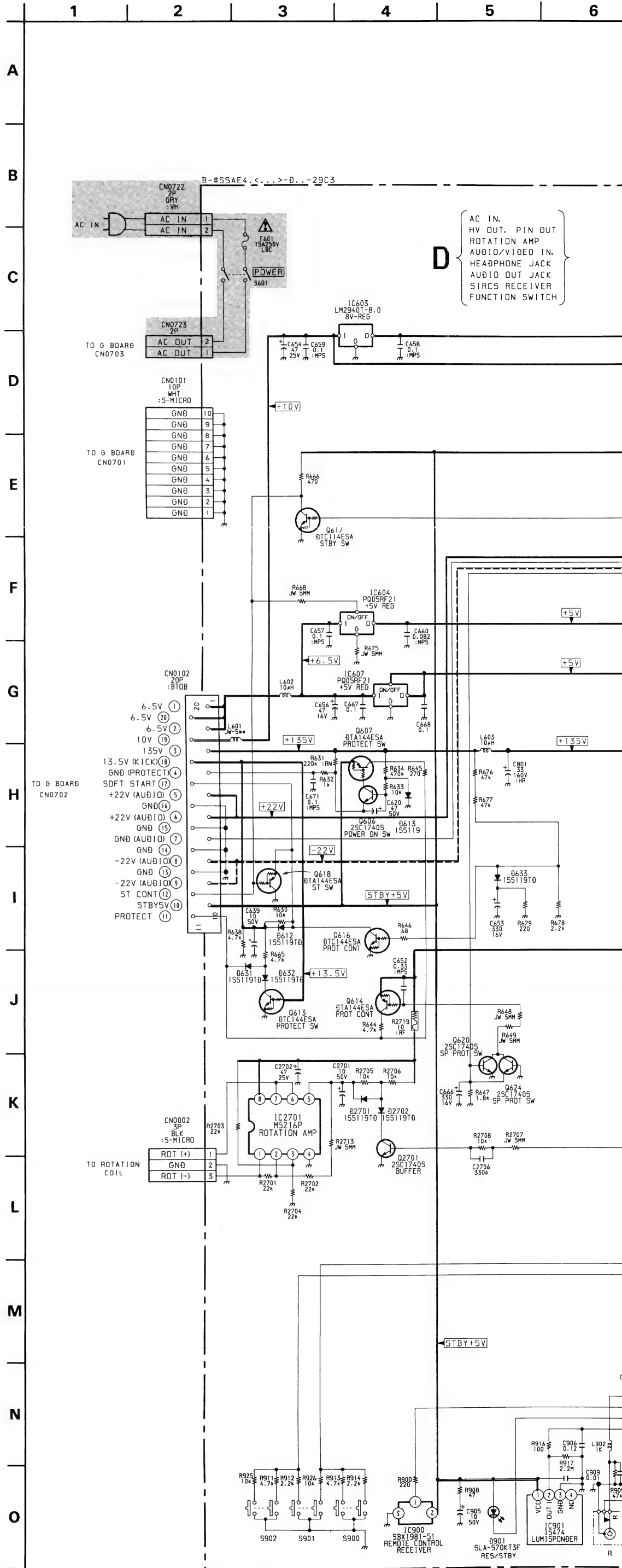

TO A (1/2) BOARD
CN101

FOR SERVICE

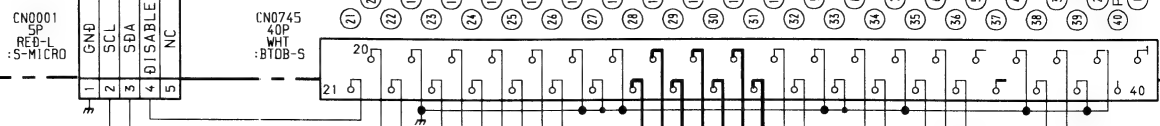

D AC IN.
HV OUT. PIN OUT
ROTATION AMP
AUDIO/VIDEO IN.
HEADPHONE JACK
AUDIO OUT JACK
SIRCS RECEIVER
FUNCTION SWITCH

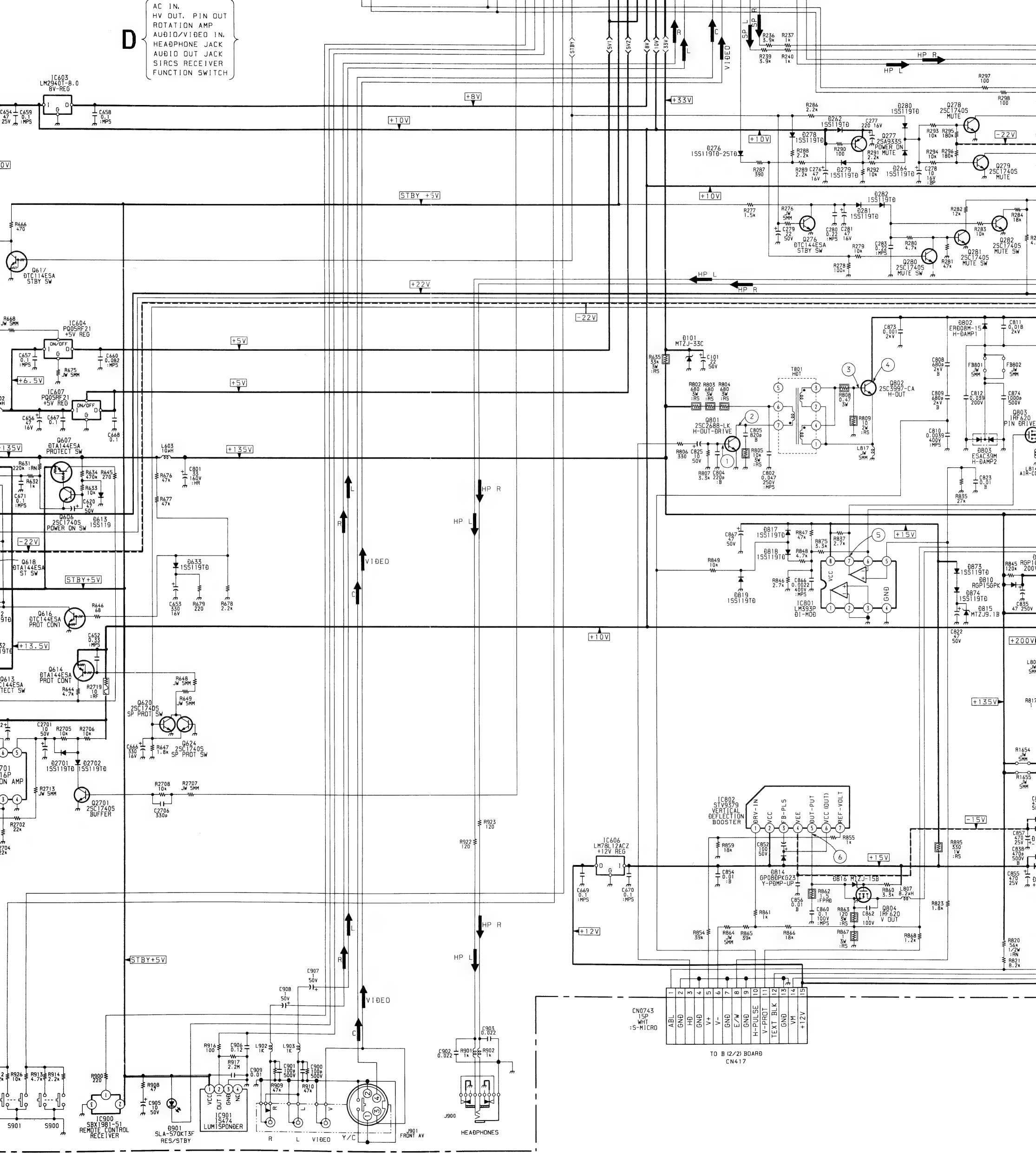

TO B (2/2) BOARD
CN417

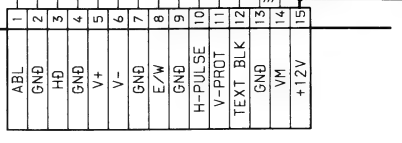

- 1 SP L
- 2 SP R
- 3 CENTER SURROUND
- 4 GND
- 5 HP L
- 6 HP R
- 7 GND
- 8 P.P.L.S L
- 9 P.P.L.S R
- 10 GND
- 11 40

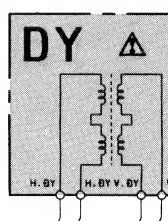
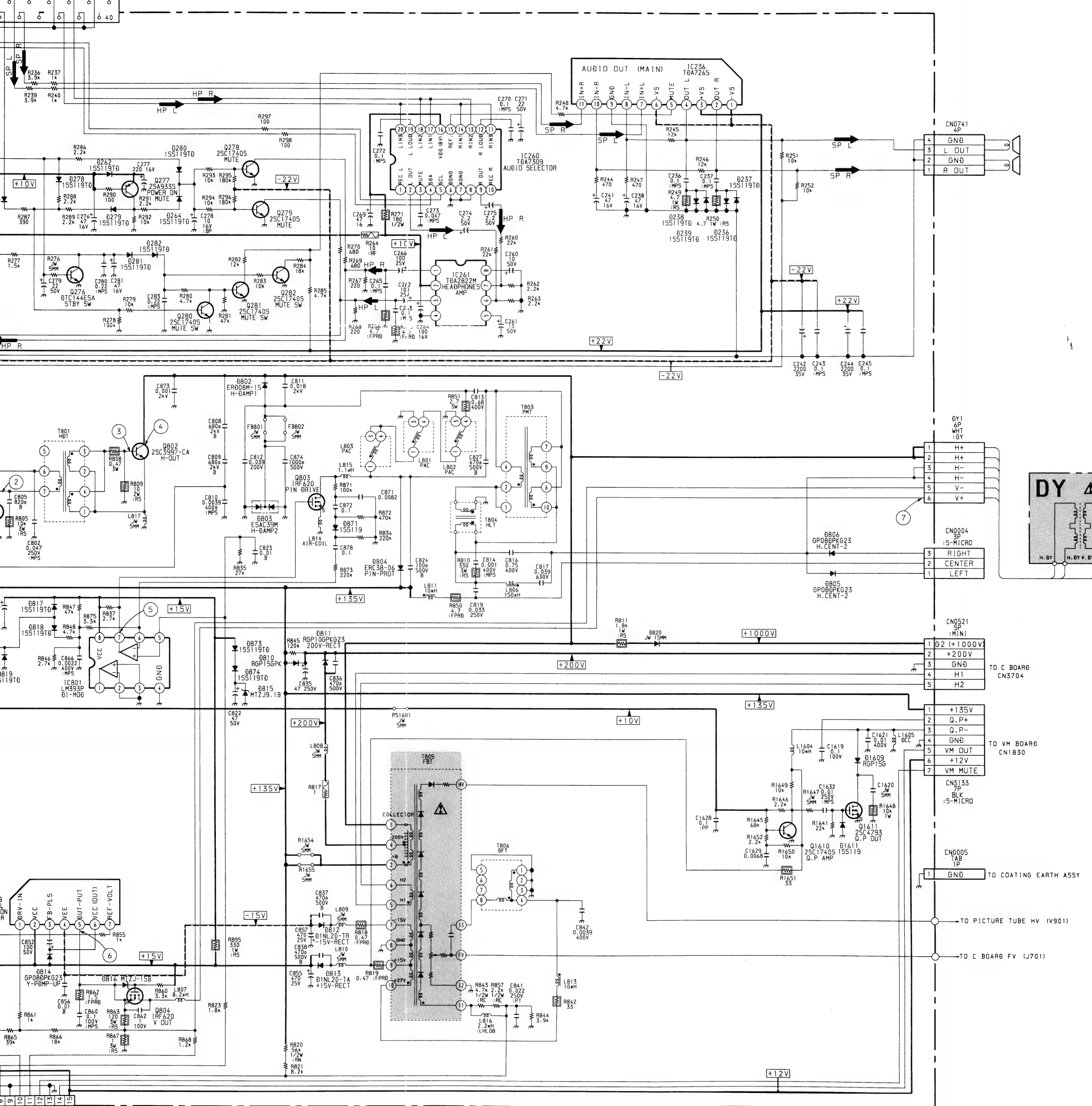

2) BOARD
17

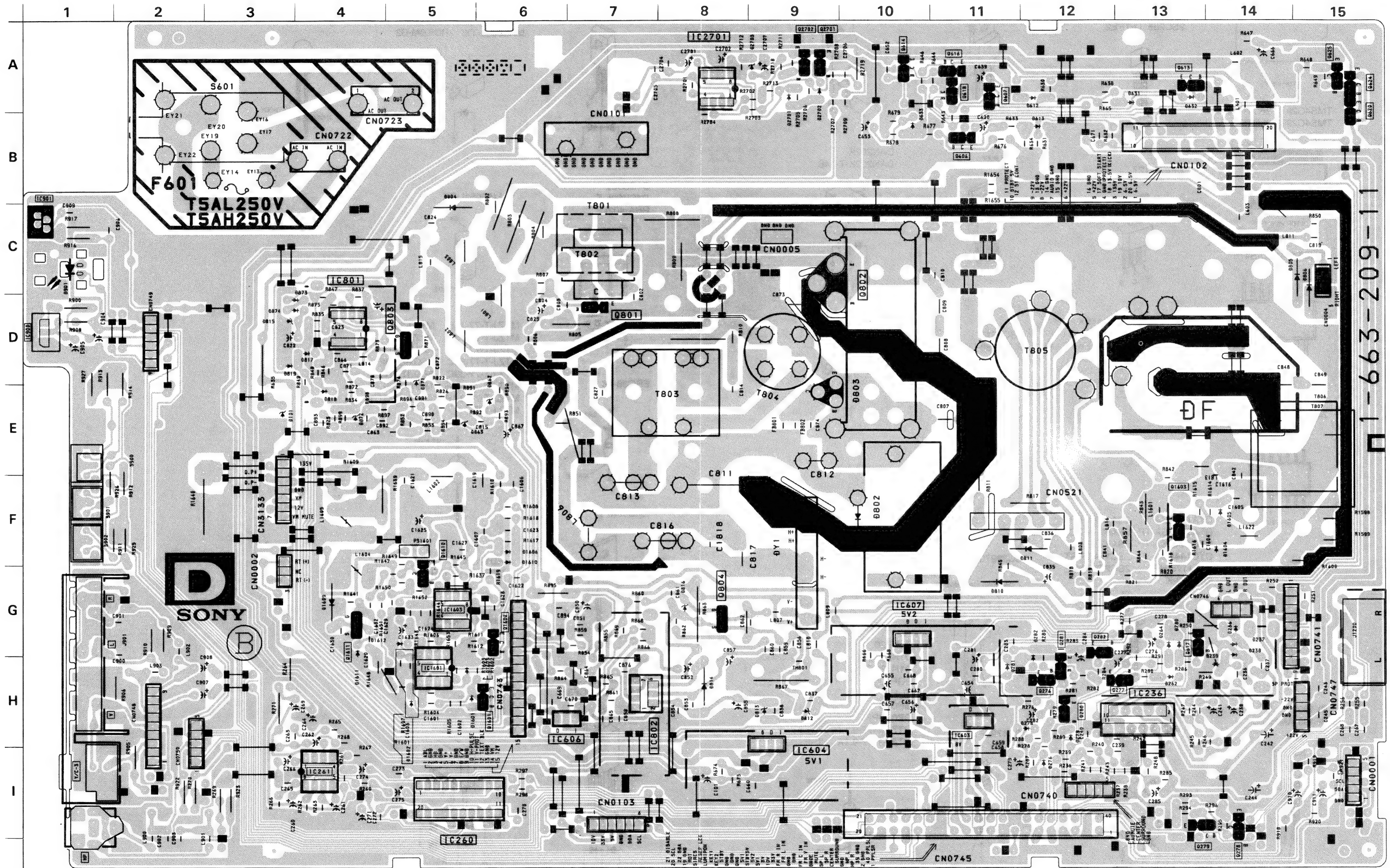

- IC236
- IC260
- IC261
- IC603
- IC604
- IC606
- IC607
- IC801
- IC802
- IC900
- IC901
- IC2701
- TRANS
- Q276
- Q277
- Q278
- Q279
- Q280
- Q281
- Q282
- Q606
- Q607
- Q613
- Q614
- Q616
- Q617
- Q618
- Q620
- Q624
- Q801
- Q802
- Q803
- Q804
- Q1610
- Q1611
- Q2701

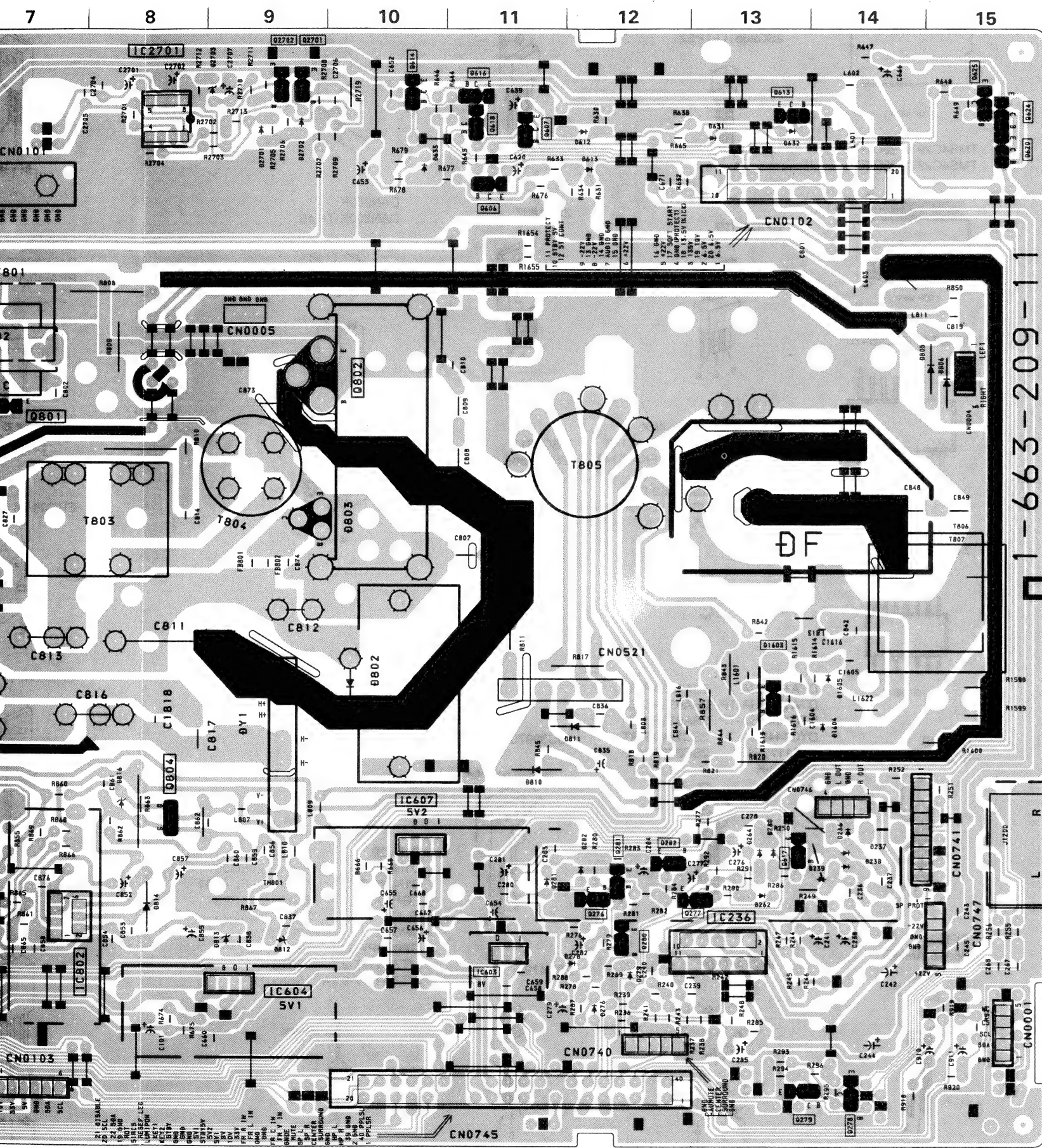

NOTE:
The circuit indicated as left contains high voltage of over 600 Vp-p. Care must be paid to prevent an electric shock in inspection or repairing.

D BOARD

IC		DIODE	
IC236	H-13	D101	E-3
IC260	I-5	D236	G-14
IC261	I-4	D237	G-14
IC603	H-11	D238	G-14
IC604	H-9	D239	G-14
IC606	H-7	D262	H-13
IC607	G-10	D264	G-13
IC801	C-4	D276	I-12
IC802	H-8	D278	H-12
IC900	D-1	D279	H-12
IC901	C-1	D280	G-13
IC2701	A-8	D281	H-12
TRANSISTOR		D282	G-12
Q276	H12	D612	A-12
Q277	H-13	D613	B-12
Q278	I-14	D631	A-13
Q279	I-14	D632	A-14
Q280	H-12	D633	B-11
Q281	G-12	D802	F-10
Q282	G-13	D803	E-10
Q606	B-11	D804	B-5
Q607	A-11	D805	C-15
Q613	A-13	D806	C-15
Q614	A-10	D810	G-11
Q616	A-11	D811	F-12
Q617	G-13	D812	H-9
Q618	A-11	D813	H-9
Q620	A-15	D814	H-8
Q624	A-15	D815	D-3
Q801	D-7	D816	G-8
Q802	C-10	D817	D-4
Q803	D-5	D818	E-4
Q804	G-8	D819	D-3
Q1610	F-5	D873	D-4
Q1611	G-4	D874	D-3
Q2701	A-9	D901	C-1
		D1609	G-4
		D1611	H-4
		D2701	A-9
		D2702	A-9

IF BOARD *MARK

Model Ref. No.	29E1A	29E1D	29E1E	29E1K	29E1R
C36	—	—	—	220MF 6.3V	220MF 6.3V
C37	—	—	—	82PF	82PF
C38	27PF	27PF	27PF	33PF	33PF
C39	—	—	—	15PF	15PF
CF02	—	—	—	6.25MHz	6.25MHz
L01	10UH	10UH	10UH	6.8UH	6.8UH
L07	—	—	—	8.2UH	8.2UH
Q10	—	—	—	2SC2412K	2SC2412K
JR5	0:CHIP	0:CHIP	0:CHIP	—	—
R20	220	220	220	180	180
R21	1K	1K	1K	3.3K	3.3K
R45	1K	1K	1K	680	680
R51	—	—	—	390	390
R53	—	—	—	27K	27K
R54	—	—	—	12K	12K
R55	—	—	—	680	680
R56	—	—	—	680	680
R57	0:CHIP	0:CHIP	0:CHIP	—	—
R59	—	—	—	680	680
R61	100	100	100	—	—



[VIF, SIF]

IF Board (KV-29E1A, 29E1D, 29E1E, 29E1K and 29E1R ONLY)

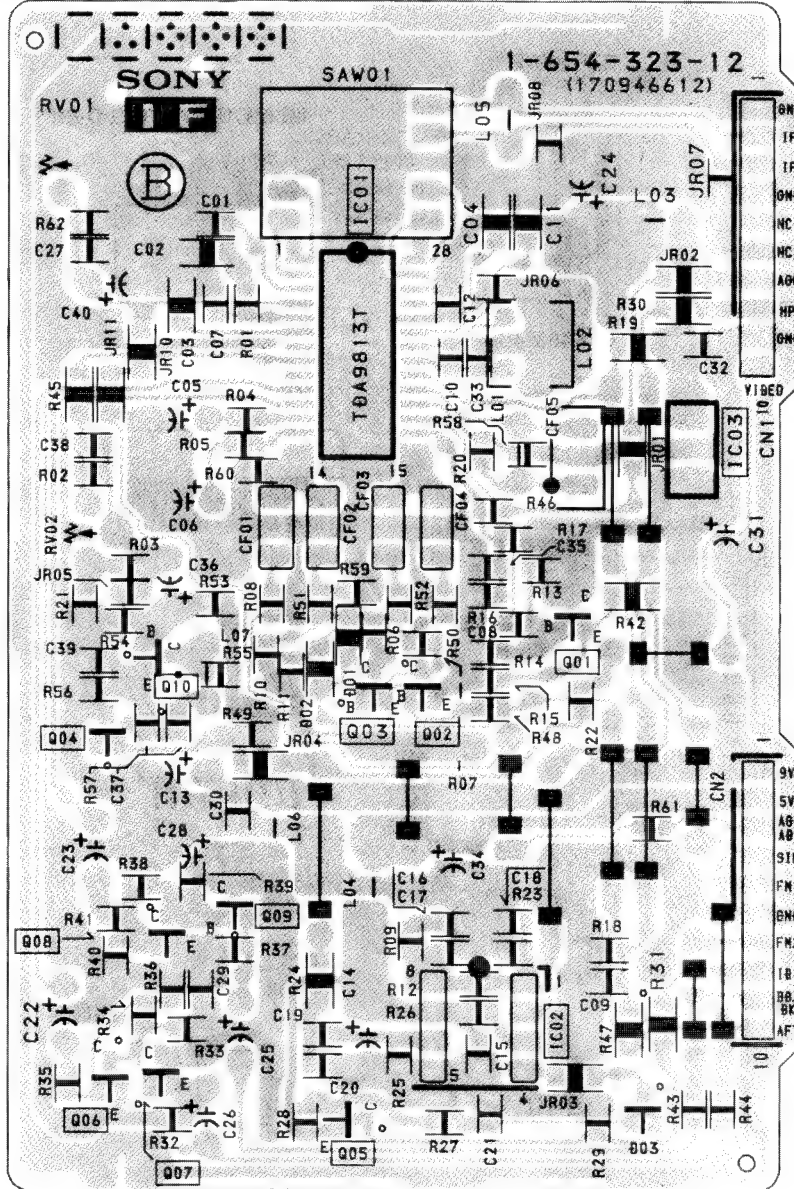

5-4. SEMICONDUCTORS

CXA1839Q-T6
CXD1178Q

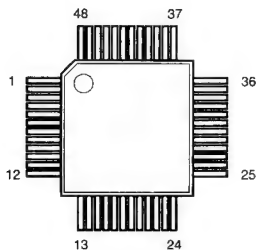

CXD2035R

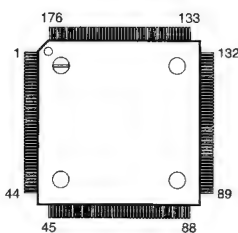

LM393P
M5216P
SDA9086-5
ST24C16CB1
TDA2822M
TEA2114
μPC393C

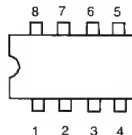

PQ09RE11
TEA7605

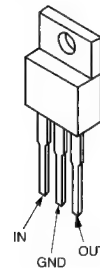

CXA1840S
CXA1855S

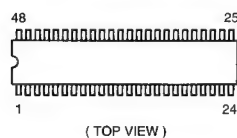

(TOP VIEW)

CXD2307R

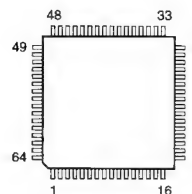

CXK48324R-1

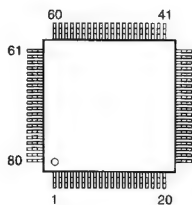

MB81C1501PFTN-G-D-ER

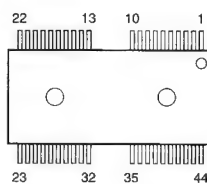

SBX1790-51

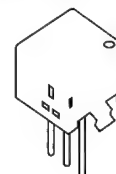

CXA1860Q-T4
CXD2300Q-T4

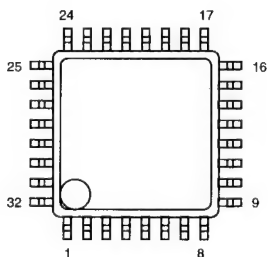

CXP85112B-646Q-TL
SAA7283GP

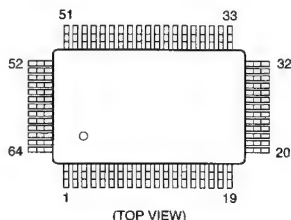

(TOP VIEW)

MB81C4256A-70PSZG

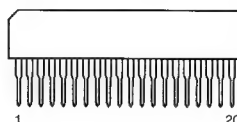

SDA30C164-GEG
SDA5273P-C26-GEG
SDA9205-2GEG

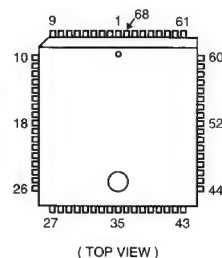

(TOP VIEW)

CXD2030R
CXD2033R-TL

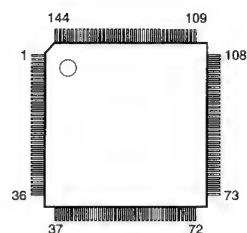

DM-48

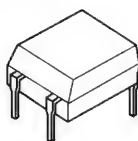

PC123F2
PC123FY2

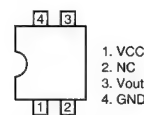

1. VCC
2. NC
3. Vout
4. GND

STV9379
TDA2052

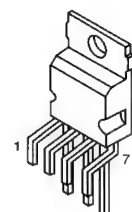

CXD2032Q-TL
CXD2036Q-TL

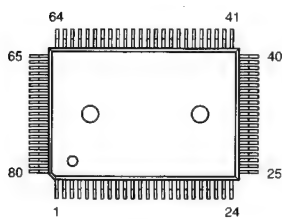

(MARKING SIDE VIEW)

LA7217M
MC74HC04AF
MC74HC74AF
SN74HC04ANS-E20
SN74HC08ANS
SN74HC86ANS-E20

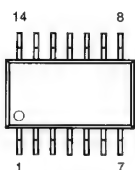

(TOP VIEW)

PQ05RF21
PQ12RF21

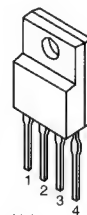

1 : V IN
2 : V OUT
3 : GND
4 : ON/OFF CONTROL

TDA6812-2MGEG

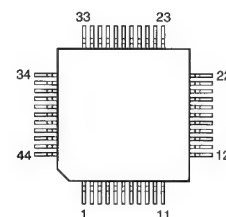

TDA7265

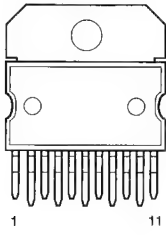

IRF610
IRF614

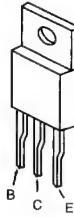

2SC4793



DA204K

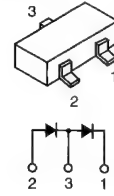

TDA8395T/N2

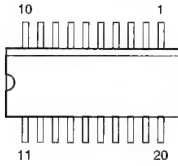

JA101 2SA1837
JC501TP 2SA733-K
2SA1091-O 2SC2500-B
2SA1207 2SC2551-O



2SC4834NP-F09



D1NL20
EL1Z
GP08D
RGP20-20EG23
RGP02-20EL-6394
RGP10GPKG23
S2LA20F

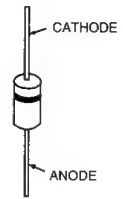

TDA8443B

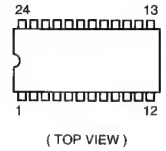

2SD774-34

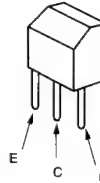

D10SC4M

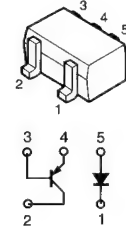

TL431CLP

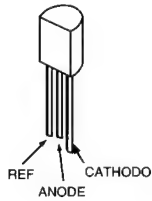

2SC2603TP-F
2SC2785-HFE

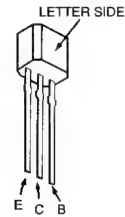

2SD2396H

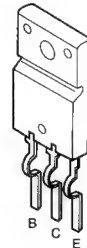

D4SB60L
RBA-402L

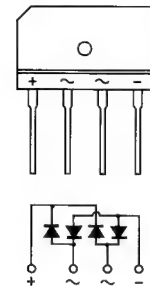

DTA114EK 2SA1037K
DTC114EK 2SA1162-G
DTC124EKA-T146 2SC2412K
DTC144EKA-T146 2SC2412K-QR

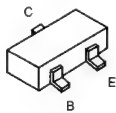

2SC2611
2SC3271-N
2SC2688-LK

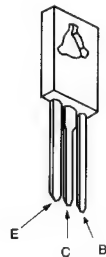

DAN202K

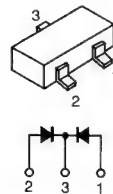

DTA144ESA
DTC144ESA



2SC3997CA

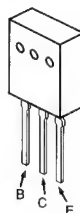

DAP202K

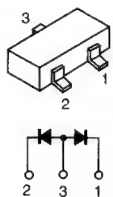

ERC38-06

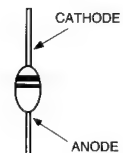

ERD08M-15

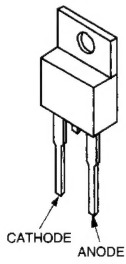

MA3039H-TX
 MA3051M-TX
 MA3091
 RB411D
 RD5.1M-B2
 RD5.6M-B2

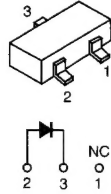

ESAC39M-06CF38
 ESAD39M-06C

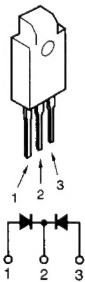

MTZJ-3.6A MTZJ-39
 MTZJ-T-77-9.1 RD39ESB2
 MTZJ-T-77-9.1A RD5.6ESB2
 MTZJ-5.6B RD6.8ESB2
 MTZJ-6.8B RD9.1ESB2
 MTZJ-9.1B RD15ESB2
 MTZJ-15B 1SS119-25
 MTZJ-33C 1SS133T-77

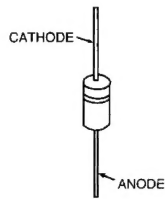

HVU359TRF
 MA110
 1SV214

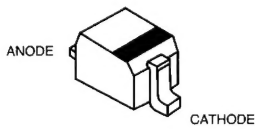

R2K-V1

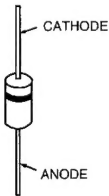

LD201VR

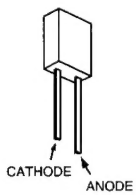

MA3030H (TX)

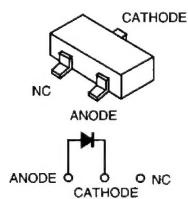

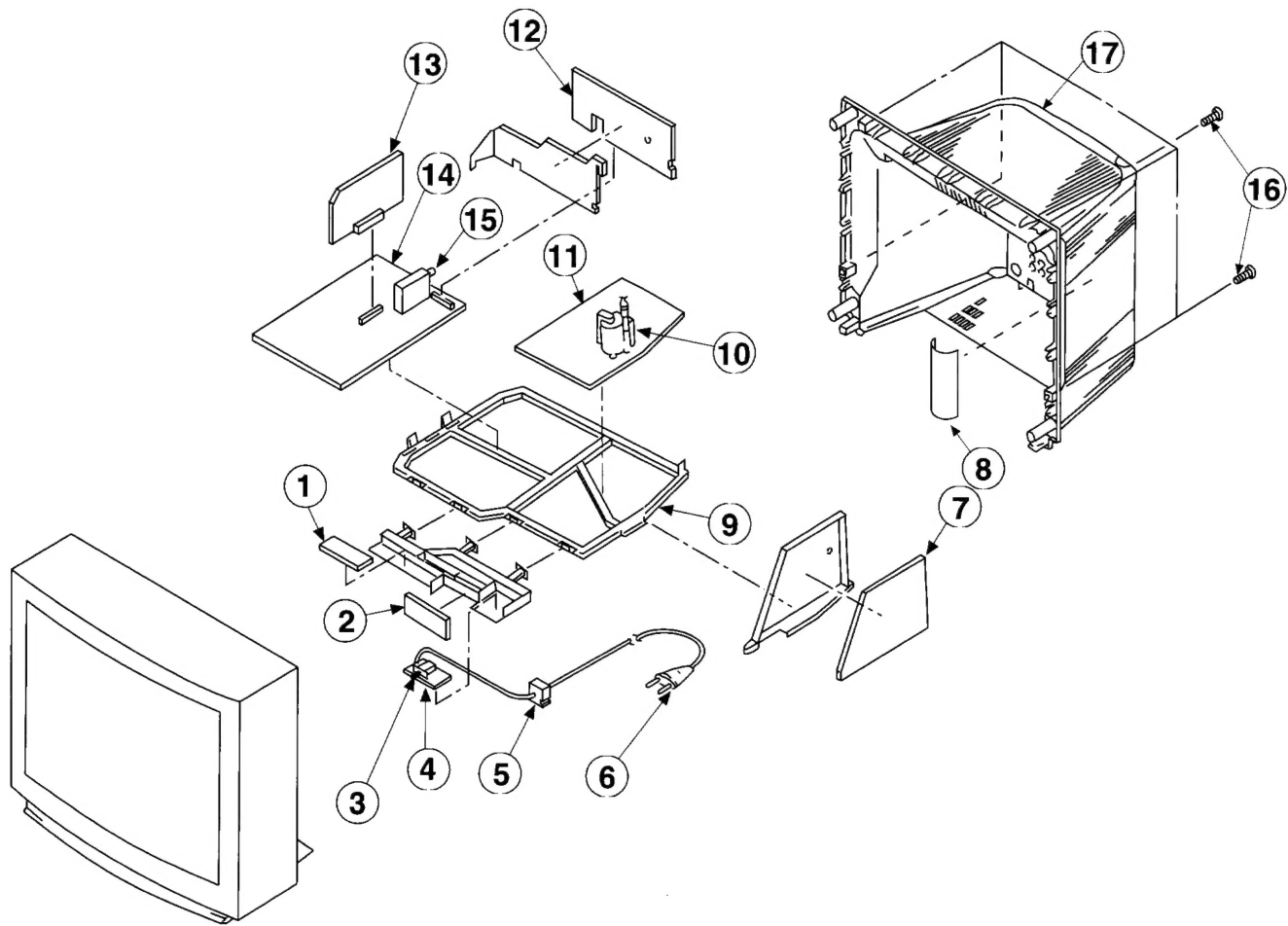

6-1. CHASSIS

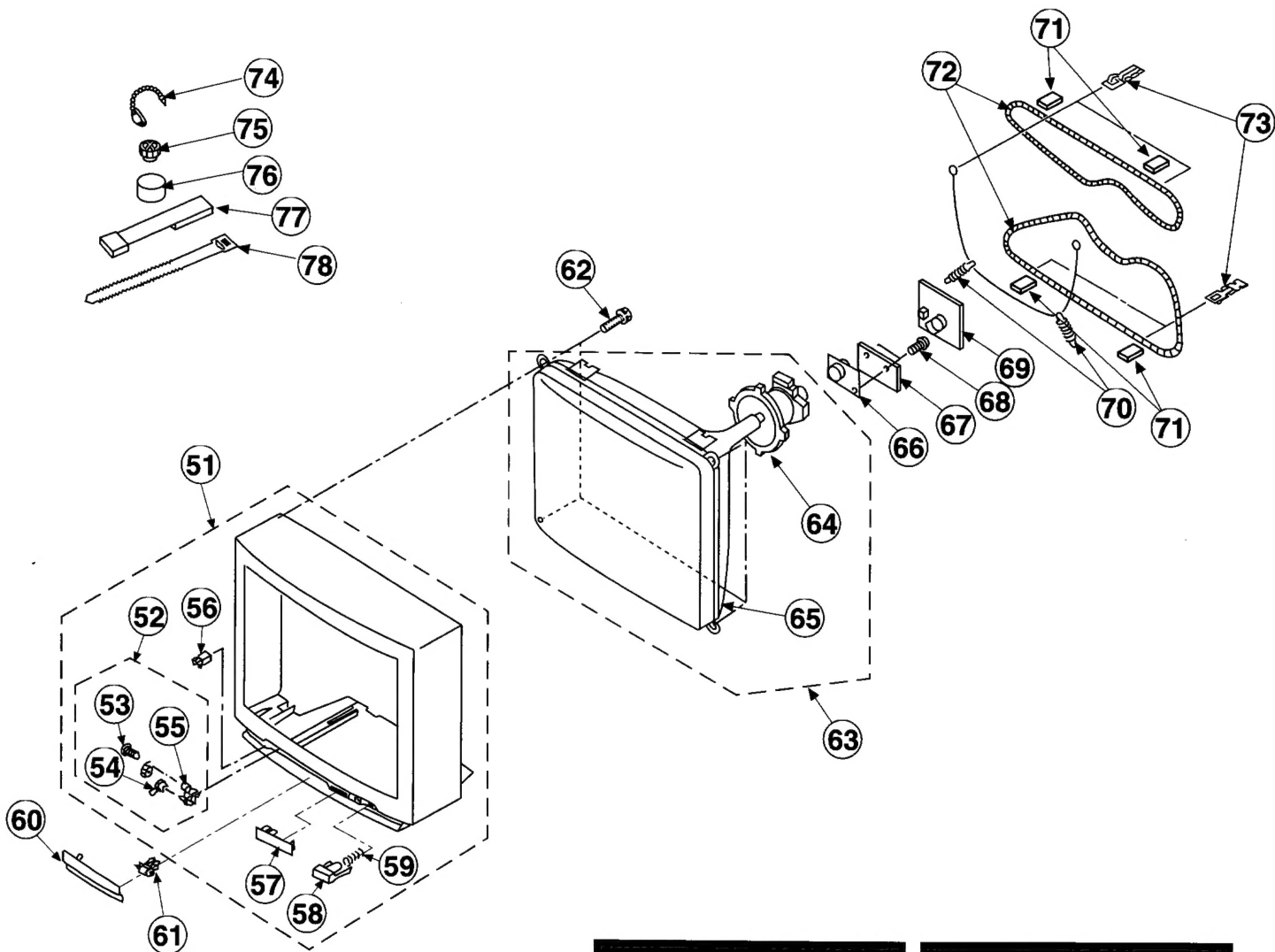

6-2. PICTURE TUBE



The components identified by shading and marked  are critical for safety. Replace only with the part number specified.

Les composants identifiés par une trame et une marque  sont critiques pour la sécurité. Ne les remplacer que par une pièce portant le numéro spécifié.

6-3. SPEAKERS

